



AMERICANFORGE&FOUNDRY™

Operation MANUAL

40 Gallon Parts Washer – Heavy Duty



Product No. 31400B



Assembly Instructions

1. Remove machine from carton and inspect for any visual damage.
2. Remove parts inside the machine.
3. Lay clean and hard cardboard on floor and lay machine on its lid. (Make sure you hold cover closed when laying machine on its lid.)
4. Mount four legs on brackets with M6 X 12 Philips head screws and M6 keps nuts.
NOTE: DO NOT TIGHTEN
5. Place lower shelf between legs with flat surface up and attach to legs with M6 X 12 Philips head screws and M6 keps nuts.
6. With legs pressed tight against lower shelf, tighten all screws to lower shelf.
7. Tighten all the screws installed in step 4.
8. Stand machine up, be careful to hold lid closed.
9. Put work shelf and basket into the machine.
10. Mount pump assembly into slot on the side of the tank and fasten to the tank using the two Philips head screws installed in the flange on the lower part of the switch housing, then place filter screen in position.
11. Plug machine into standard 115 volt 60 Hz grounded outlet as shown in *Figure A*.
12. Fill with no more than 22 Gallons of cleaning fluid.
13. Turn switch on. Fluid should now be flowing from the flexible spigot.

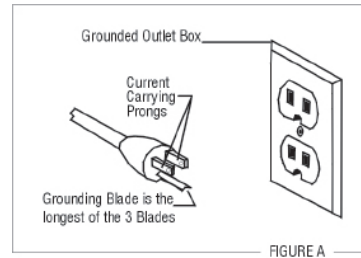

Specifications

Overall Dimensions	45-1/4" x 22" x 35"
Tank Dimensions	44-5/8" x 21-1/2" x 12-1/2"
Maximum Solvent Capacity	40 Gallons*
Working Capacity	22 Gallons
Max Pump Output Through Spigot	20L/min
Electrical Requirements	115 Volt / 60Hz / 0.5 Amp
Product Weight	99 lbs.

* DO NOT FILL TO MAXIMUM CAPACITY, FILL ONLY TO WORKING CAPACITY OF 22 GALLONS



Cleaning Solutions

Aqueous-based cleaning solution only.

WARNING

The pump of your Parts Washer may be damaged if you use solvents other than those listed above such as methyl ethyl ketone (MEK), Perchloroethylene or trichloroethylene.



Trouble Shooting

The only trouble you should ever experience with your Parts Washer is reduced volume flow or no flow of cleaning liquid from the flex hose nozzle. The probable cause is foreign matter in the flex hose.

Corrective Procedure

1. Check if indicator light on switch box is lit.
2. Using an insulated handle screwdriver, lightly touch tip of housing of motor. A light oscillation magnetic pull indicates power is reaching the motor.
3. Disconnect power plug, remove flex hose from pump flow-out line.
4. Remove front of pump housing by removing 3 screws. Clean any foreign matter lodged around impeller.
5. Reassemble in reverse order.

WARNING

1. Do not smoke near Parts Washer
2. Do not use Parts Washer near an open flame
3. Use only in a well ventilated area

Do not fill to maximum tank capacity
Fill only to 22 Gallons working capacity



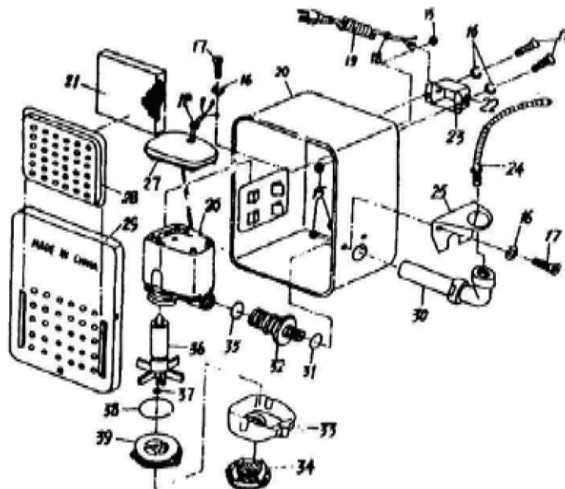
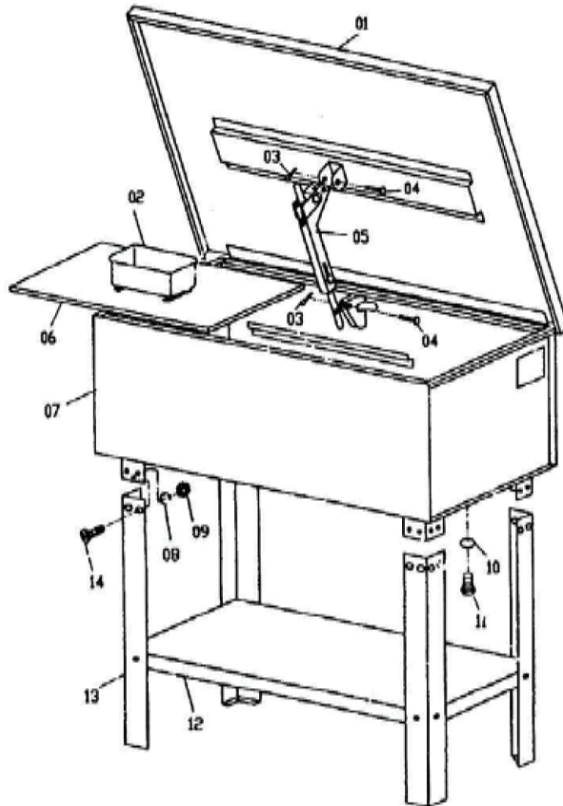

PARTS NO	DESCRIPTION	QTY
01	COVER	1
02	WORK BASKET	1
03	SPRING PAN	4
04	PIN	4
05	SAFETY PLATE	1
06	WORK SHELF	1
07	BODY	1
08	SPRING WASHER	24
09	NUT	24
10	O-RING	1
11	PLUG	1
12	SHELF	1
13	LEG	4
14	PAN SCREW	24
15	NUT	5
15	SPRING WASHER	5
17	SCREW	5
18	STRAIN RELIEF	2
19	CABLE AND PLUG	1
20	PUMP HOUSING	1
21	SCREEN	1
22	SWITCH	1
23	SWITCH BOX	1
24	FLEXIBLE PIPE	1
25	ELBOW SEAT	1
26	PUMP BODY	1
27	PUMP BACK COVER	1
28	FILTER COVER	1
29	PUMP HOUSING COVER	1
30	ELBOW	1
31	PLASTIC WASHER	1
32	SPIGOT	1
33	LOCATION OF KNOB	1
34	FILTER	1
35	SEALRING	1
36	IMPELLER	1
37	SHIN WASHER	2
38	SEALRING	1
39	IMPELLER HOLDER	1

