

Prod. No. 355123
Mod. No. JFCS-3916

Capacity:
450 lbs
(300 lbs Seat)

3-Way Low-Profile Folding Creeper/Seat *Owner's Manual*

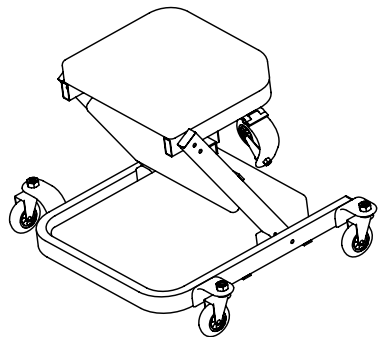
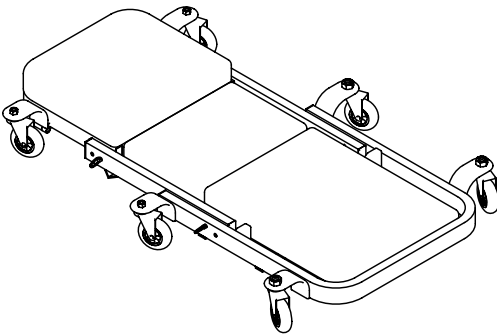
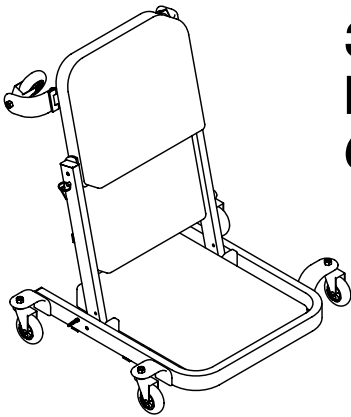

SAFETY AND GENERAL INFORMATION

For your safety, read, understand, and follow the information provided with and on this folding creeper. The owner and operator shall have an understanding of this product and safe operating procedures before attempting to use. The owner and operator shall be aware that use of this product may require special skills and knowledge. Instructions and safety information shall be conveyed in the operator's native language before use of this product is authorized. Make certain that the operator thoroughly understands the inherent dangers associated with the use and misuse of the product. If any doubt exists as to the safe and proper use of this product, remove from service immediately.

Inspect before each use. Do not use if there are broken, bent, cracked or damaged parts (including labels). Any folding creeper that appears damaged in any way, or operates abnormally shall be removed from service immediately. If the folding creeper has been

subjected to a shock load (a load dropped suddenly, unexpectedly upon it), immediately discontinue use until it has been inspected by an SureWerx authorized service center. It is recommended that an annual inspection be done by qualified personnel. Labels and Operator's Manuals are available from manufacturer.

PRODUCT DESCRIPTION

This device is designed to be folded for use as a mechanic's seat or unfolded for use as a mechanic's creeper. It is intended to be used to support and move, along a smooth and level surface, rated capacity loads consisting of a single person weighing no more than 300 lbs in the seated position for the purpose of performing automotive maintenance or service. This device is not intended, designed, or engineered to be used for any other purpose.

Rated capacity consists of: 1 person, tools, and equipment totaling 450 lbs (300 lbs seated).

⚠ WARNING

To avoid personal injury and property damage:

- Read, understand, and follow all printed materials provided with and on this product before use.
- Do not exceed rated capacity of 300 lbs in the seated position. Rated capacity consists of: 1 person, tools, and equipment totaling 450 lbs.
- Use on smooth, level, seamless surfaces only!
- Sit down gently! Avoid shock loads caused by jumping or falling onto seat.
- Do not stand on this product.
- Keep out of the reach of children! This device is not appropriate for children's use.

⚠ WARNING: Do not use this device for any purpose other than that for which it is expressly intended.

SPECIFICATIONS

Prod. No.	Model No.	Rated Capacity	Creeper Size	Cushion Size	Weight
355123	JFCS-3916	450 lbs (300 lbs seated)	40" x 26" x 4.75"	39" x 13"	25.8 lbs

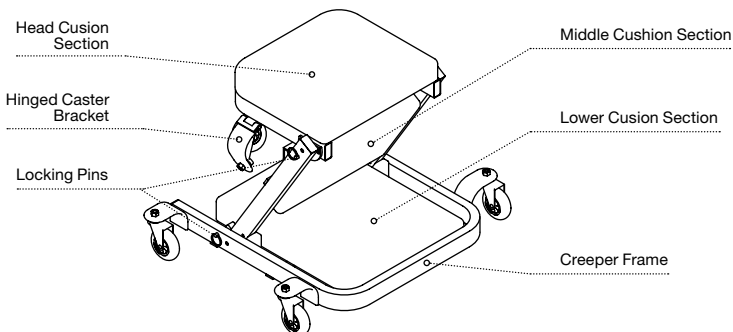

PREPARATION

Before assembling your Folding Creeper, make sure all parts are present. Compare parts with package contents list and illustrations. If any part is missing or damaged, do not attempt to assemble, install or operate the product. Contact SureWerx customer service for replacement parts.

Packaging Contents: 1 Creeper Body with Cushions, 6 Casters, 6 Caster Lock Nuts.

ASSEMBLY

1. Carefully unfold the creeper until flat. Engage spring-loaded Locking Pins.

⚠ CAUTION: *Folding components can present pinch and crush hazards during normal use of this product. Exercise caution when performing adjustments and while assembling and using this equipment.*

2. Attach Casters to creeper frame castor brackets using 17 mm nuts.

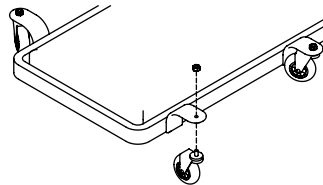

OPERATION

1. Locate and unlock spring-loaded Locking Pin for middle section by pulling out until disengaged. Then rotate Head Frame and Middle Frame upward as shown in Fig. 1 until the Locking Pin can engage hole in Creeper Seat locking plate (ensure Lock Pin is fully engaged). This is the low seat configuration.
2. Disengage Lock Pin for Middle Frame and rotate further forward. Engage locking pin. Disengage Lock Pin for Head Frame section and rotate backwards as shown in Fig. 2. Adjust hinged castor brackets as required. This is the high seat configuration.

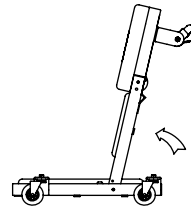

Figure 1 – Low-seat configuration

⚠ CAUTION: *Ensure all Lock Pins are properly engaged before using creeper.*

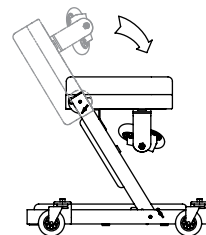

Figure 2 – High-seat configuration

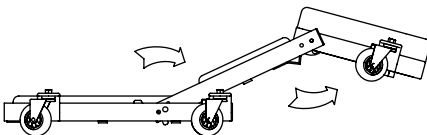

Figure 3 – Creeper configuration

3. Adjust hinged castor brackets so wheels will contact ground properly. Unlock spring-loaded Lock Pins, then reverse steps 1 and 2, as shown in Fig. 3, to convert Creeper Seat into Creeper.

MAINTENANCE

Wipe clean as needed. Use mild upholstery cleaner (not caustic) to clean cushions.

⚠ CAUTION: Do not add lubricant to casters.

REPLACEMENT PARTS LIST

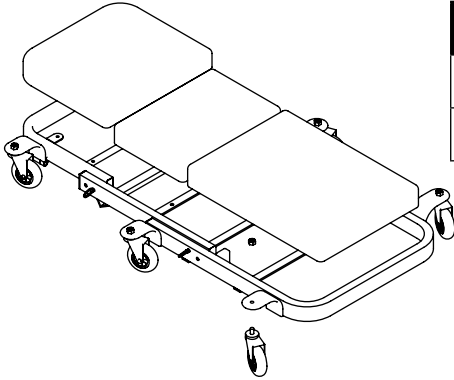

Item	Part No.	Description	Qty
1	PCN-JFCS3916-1	Caster Assembly	6
2	PCN-JFCS3916-2	Hardware Assembly	1