

NEW Heritage Brick Cast-in-Place Composite Paver™

Designed with a high definition brick pattern, the Heritage Brick paver allows you to incorporate the classic look of brick pavers without sacrificing safety or ADA compliance.

- **Eliminates trip hazards and maintenance issues**
- **More durable than brick or concrete pavers**
- **Based on proven ADA paver design**
- **ADAAG / PROWAG compliant**
- **Available in standard and new Stonescape UV+ colors**

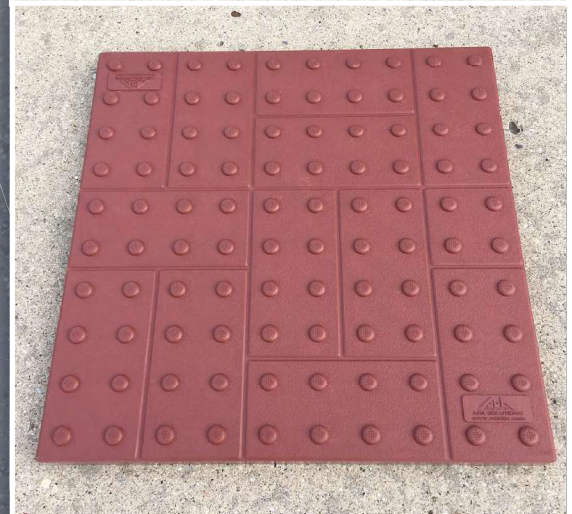

Heritage Brick

Cast-in-Place Composite Paver

available in two sizes; 24"x24" and 24"x30"

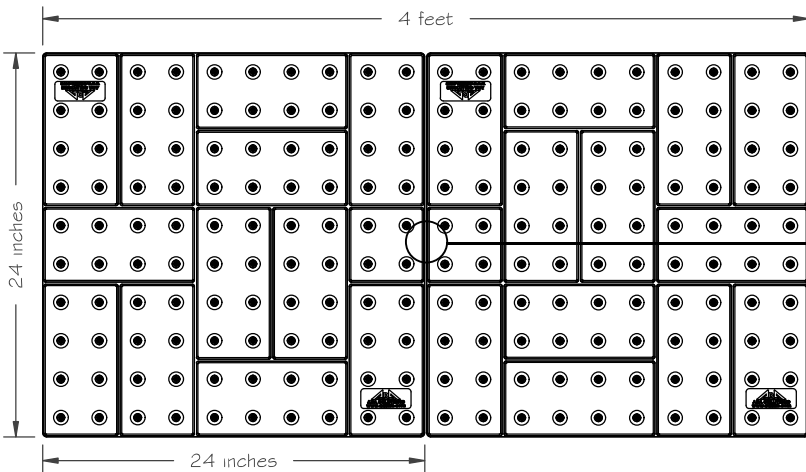
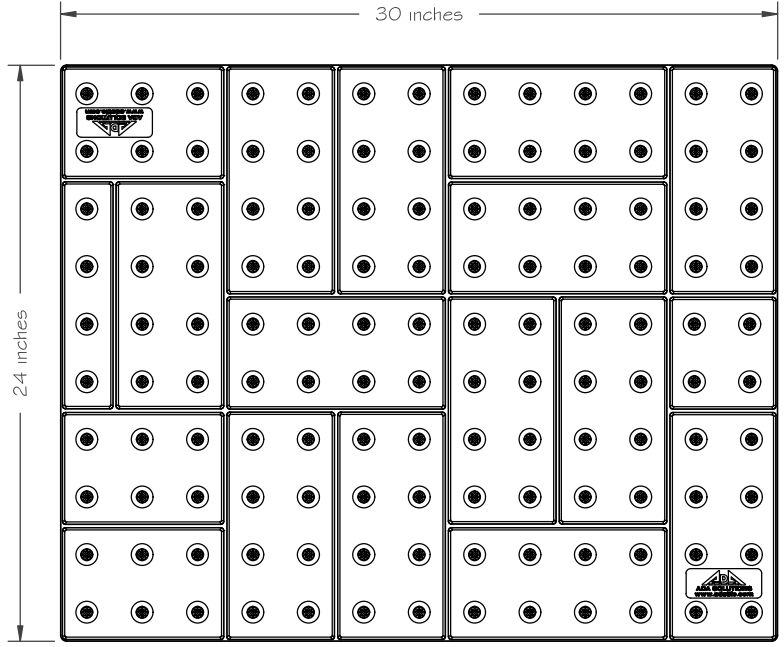
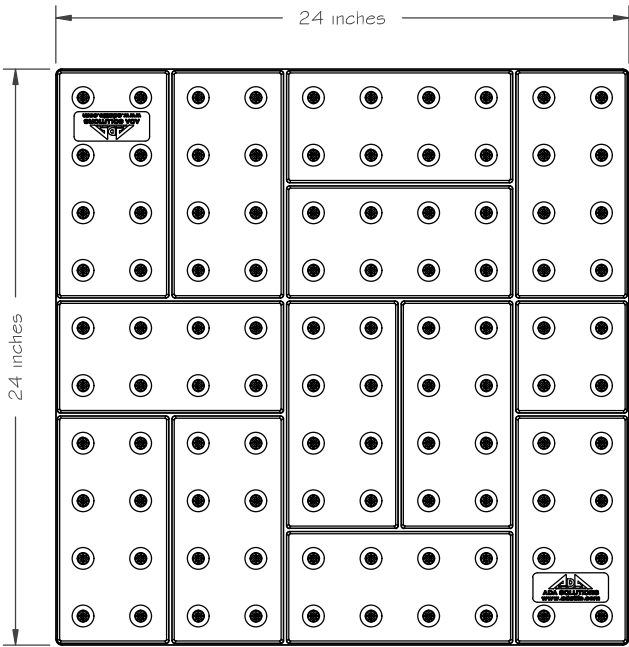

Half
brick
location
on each
panel

These sizes can be combined and configured to fit standard sidewalk widths of 4ft or 5ft. The basketweave brick pattern is easily and seamlessly kept consistent by matching the half brick located on each panel.

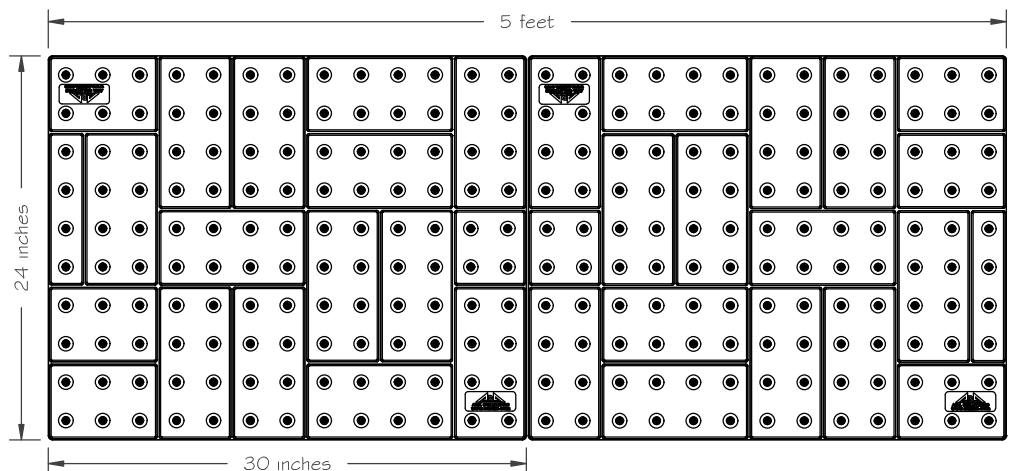

For more detailed instructions or assistance with paver layouts and configurations to meet your needs, contact your ADA sales representative.



PRODUCT DATA SHEET:

SECTION 32 17 26 – TACTILE WARNING SURFACING
DETECTABLE WARNING SURFACE PANELS
HERITAGE BRICK CAST-IN-PLACE COMPOSITE PAVER

Manufacturer:

ADA Solutions, a Division of SureWerx USA Inc.
149 South Cucumber Street
Jefferson, Ohio 44047
Phone: 800-372-0519
Fax: 978-262-9125
Web: adatile.com

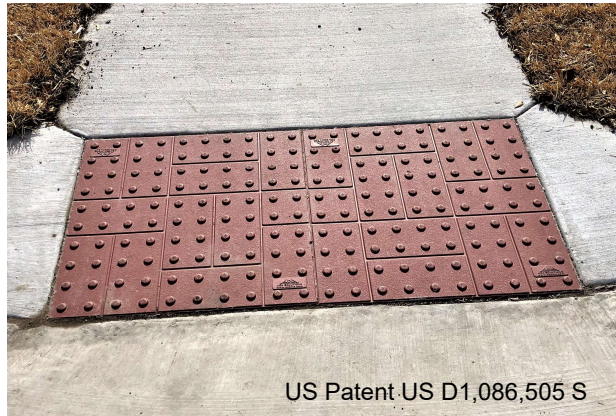

US Patent US D1,086,505 S

Description: Heritage Brick Cast-In-Place Composite Paver Detectable Warning Surface Panels (HB Paver) with an in-line truncated dome pattern embedded in concrete at pedestrian crossings, boarding platforms, and rail crossing locations. The HB Paver has a unique surface pattern that mimics the appearance of classic brick paver units.

Compliance: HB Paver panels are compliant with the following guidelines and requirements:

- American Barriers Act (ABA) Accessibility Standards
- ADA Accessibility Guidelines (ADAAG)
- Department of Transportation ADA Standards for Transportation Facilities (2006)
- Department of Justice ADA Standards (2010)
- Public Rights-of-Way Accessibility Guidelines (PROWAG)
- Texas Accessibility Standards (TAS) 2012
- AASHTO M 333 Standard Specification for Detectable Warning Surfaces
- International Code Council (ICC) A117.1 Accessible and Usable Buildings and Facilities

Material: HB Paver panels are manufactured using a matte finish exterior grade homogeneous (uniform color throughout thickness of product) glass and carbon reinforced polyester-based sheet molding compound (SMC) composite material.

Warranty: Guaranteed in writing for a period of seven (7) years from date of Contract's final completion. The guarantee includes manufacturing defects, breakage, and deformation.

Panel Sizes:

24" x 24" (609.6 x 609.6 mm)
24" x 30" (609.6 x 762 mm)

Colors: Color shall be homogeneous color throughout panel

- Federal Yellow FS No. 33538
- Brick Red FS No. 20109
- Clay Red FS No. 22144
- Safety Red FS No. 31350
- Black FS No. 37038
- Dark Gray FS No. 36118
- Safety Blue FS No. 15187
- White FS No 27925
- Seattle Yellow FS No 23594

Domes: Raised truncated domes of 0.2" (5.0 mm) nominal height, base diameter of 0.9" (22.8 mm) and top diameter of 0.45" (11.4 mm).

Dome Spacing: HB Paver panels have 2.31" (58.6 mm) or 2.4" (60.9 mm) dome spacing in square grid pattern. ADA Standards and Public Rights-of-Way Accessibility Guidelines require truncated dome spacing range of 1.6"-2.4" (40.6-60.9 mm).

Anchoring: HB Paver panels feature structural embedment ribs on the reverse side of the panel located at 3" (76.2 mm) on center. The ribs provide structural support to the panel surface and secure the panel permanently into the cured concrete substrate.

Installation: HB Paver panels are wet set into a minimum 2 ½" (63.5 mm) depth of concrete (4"-7" slump). Panels are pressed into the wet concrete and tamped or vibrated to ensure that there are no voids or air pockets. Field level of the panel is to be flush to the adjacent concrete surface. Multiple panels can be installed in series to match specific curb ramp widths or length of specific installation.

Cutting: HB paver panels can be cut to size using a 60-tooth carbide blade on a table saw or equivalent cutting device.

PRODUCT DATA SHEET:

SECTION 32 17 26 – TACTILE WARNING SURFACING
DETECTABLE WARNING SURFACE PANELS
HERITAGE BRICK CAST-IN-PLACE COMPOSITE PAVER

Product Testing and Physical Properties:

Standard	Standard Description	Value
ASTM D695	Compressive Strength	28,900 psi minimum
ASTM D790	Flexural Strength	29,300 psi minimum
ASTM D 638	Tensile Strength	11,600 psi minimum
ASTM C 1028	Standard Test Method for Determining the Static Coefficient of Friction (Slip Resistance)	1.18 Dry / 1.05 Wet
AS HB198:2014 (AS/NZS 4586)	Pendulum Sustainable Slip Resistance (SSR)	Pendulum Test Value (PTV), with Four S (96) hard rubber slider: 56 Dry / 44 Wet; After 500 cycles of abrasion: 34 Wet
ASTM C501	Abrasion Resistance	Minimum 500
FM 5-594	Abrasion Resistance, Florida Method	Average Volume Loss: no more than 0.03 cm ³
NTPEP TP103 (2015)	High Temperature Thermal Cycling Exposure, (Sect 14) and Resistance to Impact from Falling Tup (Sect 10)	Min. 60 thermal cycles at 200°F (93.33°C) = maximum damage classification of 'C' at 20 ft-lb impact
ASTM G155	Accelerated Weathering	$\Delta E < 5.0$ at 2,000 hours min.
ASTM D570	Water Absorption	0.07%
ASTM C1026	Freeze/Thaw/Heat	No deterioration
ASTM D1037	Freeze/Thaw	No deterioration
ASTM D543	Chemical Stain Resistance	No reaction
ASTM D1308	Chemical Stain Resistance	No reaction
ASTM-B117	Salt and Spray	No change after 200 hours
ASTM E84	Flame Spread Index	20
AASHTO H20	Load Bearing Test	No Damage at 16,000 lbs.



SECTION 32 17 26 – TACTILE WARNING SURFACING

DETECTABLE WARNING SURFACE PANELS HERITAGE BRICK CAST-IN-PLACE PAVER™

SECTION 1 - GENERAL

1.1 DESCRIPTION

- A This Section includes Specifications for furnishing and installing permanently embedded Heritage Brick Cast-In-Place Paver™ (HB-CIP) Detectable Warning Surface Panels with an in-line truncated dome pattern embedded in concrete at pedestrian crossings, boarding platforms, and rail crossing locations to the dimensions shown on the Drawings, in accordance with the Contract Documents and as directed by the Engineer.

1.2 RELATED DOCUMENT

- A Drawings and general provisions of Contract, including General and Special Conditions and Division 1 Specifications Section, apply to this Section.
- B Department of Justice ADA Standards (2010)
- C Department of Transportation ADA Standards for Transportation Facilities (2006)
- D Proposed Guidelines for Accessible Public Rights-of-Way (2011)
- E California Title 24
- F ISO 23599:2019-01 – Assistive products for blind and vision-impaired persons — Tactile walking surface indicators
- G ISO 21542:2011 – Building Construction – Accessibility and Usability of the Built Environment
- H ISO 9001 – Certificate No. 0502011, ISO 1409 and ISO/B 16949 Certified Manufacturing Facility located in Jefferson, OH
- I Accessibility for Ontarians with Disabilities Act - (AODA)
- J Canadian Standards Association – (CSA)

1.3 SUBMITTALS

- A Product Data Sheet: Submit ADA Solutions literature describing products, installation procedures and routine maintenance.
- B Samples for Verification Purposes: Submit two (2) detectable warning surface panel samples. Samples shall be properly labeled and shall contain the following information: Name of Project, Submitted By, Date of Submittal, and Manufacturer's Name.

- C Shop Drawings: Submit the Standard Manufacturer Shop Drawings showing all pertinent characteristics of the Detectable Warning Surface Panels including profile, panel surface profile, plans of panel placement including joints, and material to be used as well as outlining installation materials and procedures.
- D Material Test Reports: Submit all completed current test results from qualified, accredited independent testing laboratories by ASTM and UL/Canada guidelines and indicating that materials proposed for use follow specification requirements and meet or exceed the properties indicated on these specifications.
- E Maintenance Instructions: Submit copies of the manufacturer’s specified installation and maintenance practices for each type of Detectable Warning Surface panels and accessories as required.

1.4 QUALITY ASSURANCE

- A Provide Detectable Warning Surface Panels and accessories as produced by a single manufacturer with a minimum of five years of experience in manufacturing Cast-In-Place Composite Shell Detectable Warning Surface Panels.
- B Installer’s Qualifications: Engage an experienced installer certified in writing by Detectable Warning Surface Panel manufacturer as qualified for installation, who has completed installations similar in material, design, and extent to that indicated for the Contract.
- C Detectable Warning Surface Panels must be compliant with the following guidelines and requirements (applicability may be dependent on project location):
 - 1. American Barriers Act (ABA) Accessibility Standards
 - 2. ADA Accessibility Guidelines (ADAAG)
 - 3. Department of Transportation ADA Standards for Transportation Facilities (2006)
 - 4. Department of Justice ADA Standards (2010)
 - 5. Public Rights-of-Way Accessibility Guidelines (PROWAG)
 - 6. California Building Standards Code, Title 24, California Code of Regulations
 - 7. Texas Accessibility Standards (TAS) 2012
 - 8. AASHTO M 333 Standard Specification for Detectable Warning Surfaces
 - 9. International Code Council (ICC) A117.1 Accessible and Usable Buildings and Facilities
- D Detectable Warning Surface Panels shall meet or exceed the following test criteria using the most current test methods:

Standard	Standard Description	Value
ASTM D695	Compressive Strength	28,900 psi minimum
ASTM D790	Flexural Strength	29,300 psi minimum
ASTM D 638	Tensile Strength	11,600 psi minimum
ASTM C 1028	Standard Test Method for Determining the Static Coefficient of Friction (Slip Resistance)	1.18 Dry / 1.05 Wet
AS HB198:2014 (AS/NZS 4586)	Pendulum Sustainable Slip Resistance (SSR)	Pendulum Test Value (PTV), with Four S (96) hard rubber slider: 56 Dry / 44 Wet; After 500 cycles of abrasion: 34 Wet
ASTM C501	Abrasion Resistance	500 minimum
FM 5-594	Abrasion Resistance, Florida Method	Average Volume Loss: no more than 0.03 cm ³

NTPEP TP103 (2015)	High Temperature Thermal Cycling Exposure, (Sect 14) and Resistance to Impact from Falling Tup (Sect 10)	Min. 60 thermal cycles at 200°F (93.33°C) = maximum damage classification of 'C' at 20 ft-lb impact
ASTM G155	Accelerated Weathering	$\Delta E < 5.0$ at 2,000 hours min.
ASTM D570	Water Absorption	0.07%
ASTM C1026	Freeze/Thaw/Heat	No deterioration
ASTM D1037	Freeze/Thaw	No deterioration
ASTM D543	Chemical Stain Resistance	No reaction
ASTM D1308	Chemical Stain Resistance	No reaction
ASTM-B117	Salt and Spray	No change after 200 hours
ASTM E84	Flame Spread Index	20
AASHTO H20	Load Bearing Test	No Damage at 16,000 lbs.

- E Stamped concrete, polymer concrete, concrete pavers/tile, or brick products are not acceptable for use on this project.
- F Panels shall have four (4) side perimeter flanges a minimum length of 1.3" (33 mm); interior embedment flanges spaced a maximum of 3" (76.2 mm).

1.5 DELIVERY, STORAGE AND HANDLING

- A Detectable Warning Surface Panels shall be suitably packaged or crated to prevent damage in shipment and handling. Finished surfaces shall be protected by sturdy plastic wrappings to protect the panel from concrete residue during installation.
- B Detectable Warning Surface Panels shall be delivered to a location at the building site for storage before installation. Store panels in an area that is within an acceptable temperature range 40°F - 90°F (4°C - 32°C) and maintain the storage facility in a clean, dry condition to prevent contamination or damage to the panels.

1.6 SITE CONDITIONS

- A Environmental Conditions and Protection: Maintain a minimum temperature of 40°F (4°C) in spaces to receive Detectable Warning Surface Panels for at least 24 hours before installation, during installation, and for not less than 24 hours after installation.
- B The use of water for work, cleaning, or dust control, etc. shall be contained and controlled and shall not be allowed to come in to contact with the general public. Provide barricades or screens to protect pedestrians.

1.7 MANUFACTURER'S WARRANTY

- A Detectable Warning Surface Panels shall be guaranteed in writing for a period of seven (7) years from date of Contract's final completion. The guarantee includes manufacturing defects, breakage, and deformation.

1.8 INSTALLATION WARRANTY

- A Detectable Warning Surface Panels installation shall be warranted in writing for two (2) years by the installer. Products must be guaranteed from defective work and loosening of panels.

SECTION 2 – PRODUCTS

2.1 MANUFACTURERS

- A. Heritage Brick Cast-In-Place Paver (HB-CIP) Detectable Warning Surface Panels by ADA Solutions, 149 South Cucumber Street, Jefferson, Ohio 44047. Toll-Free: 800-372-0519, sales@adatile.com, www.adatile.com.
- B. Panel Sizes
 - a. 24" x 24" (609.6 x 609.6 mm)
 - b. 24" x 30" (609.6 x 762.0 mm)
- C. Existing engineered and field-tested products, which have been in successful service for five (5) years are subject to specification compliance, may be incorporated in the project and shall meet or exceed the specified test criteria and characteristics. Requests for Approved Equal status must be submitted and approved by the Owner before the Tender Phase of the project.

2.2 MATERIALS

- A. Composition: Heritage Brick Cast-In-Place Paver (HB-CIP) Detectable Warning Surface Panels shall be manufactured using a matte finish exterior grade homogeneous (uniform color throughout thickness of product) glass and carbon reinforced Sheet Molding Compound (SMC) composite material. Truncated domes must contain fiberglass reinforcement within the truncated dome for superior structural integrity and impact resistance. A matte finish will be required on the Tactile Warning Surface for superior slip resistance performance superior to that offered by a gloss finish. Use of Tactile Warning Surface Products employing coatings or featuring layers of material with differing composition, performance, or color properties is expressly prohibited under this Section.
- B. Brick Pattern: Heritage Brick Cast-In-Place Paver (HB-CIP) Detectable Warning Surface Panels shall have simulated brick joint lines recessed below the top walking surface. Pattern of simulated joint lines to be modified basket weave.
- C. Color: Color shall be single, homogeneous color throughout panel:
 - 1. Federal Yellow (Y), Federal Standard Color No. 33538
 - 2. Brick Red (R), Federal Standard Color No. 20109
 - 3. Clay Red (CR) Federal Standard Color No. 22144
 - 4. Safety Red (SR) Federal Standard No. 31350
 - 5. Black (B) Federal Standard Color No. 37038
 - 6. Dark Gray (G) Federal Standard Color No. 36081
 - 7. Safety Blue (B) Federal Standard Color No. 15187
 - 8. White (W) Federal Standard Color No 27925
 - 9. Seattle Yellow (SY) Federal Standard Color No. 23594
- D. Domes: Square grid pattern of raised truncated domes of 0.2" (5 mm) nominal height, base diameter of 0.9" (22.8 mm) and top diameter of 0.45" (11.4 mm). Dome spacing to be 2.31"-2.40" (58.6-60.9 mm).
- E. Configuration: HB-CIP panels sizes shall be as indicated on the Contract Drawings. For superior load bearing capacity, HB-CIP panels shall feature internal embedment ribs at 3" (76.2 mm) on center maximum. The field area shall consist of a non-slip textured surface.
- F. Truncated Dome Surface of HB-CIP panels shall be protected with factory installed plastic sheeting for cleanliness during the installation process. Basic Installation Guidelines shall be printed on the plastic sheeting in both English and Spanish for customer convenience.

- G. Cleaning materials used on site shall have code acceptable low VOC solvent content and low flammability.
- H. The Specifications of the concrete, sealants and related materials shall be in accordance with the Contract Documents and the guidelines set by their respective manufacturers.

SECTION 3 - EXECUTION

3.1 PREPARATION

- A. During all concrete pouring and panel installation procedures, ensure adequate safety guidelines are in place and that they are in accordance with the applicable industry and government standards.
- B. The physical characteristics of the concrete shall be consistent with the Contract Specifications while maintaining a slump range of 4 - 7 to permit solid placement of the panel. An overly wet mix will cause the panel to float. Under these conditions, suitable weights such as 2 concrete blocks or sandbags (25 pounds) shall be placed on each panel.
- C. The concrete shall be poured and finished, true and smooth to the required dimensions and slope prior to panel placement.

3.2 EQUIPMENT

- A. Contractor shall provide all tools, equipment, and services required for satisfactory installation per manufacturer's instruction as Incidental Work. Equipment which may be required include typical mason's tools, a 4-foot level with electronic slope readout, 25 lb. (11.4 kg) weights, vibrator, rubber mallet with 2" x 4" x 10" (51 mm x 102 mm x 254 mm) wood tamping plate, and a device for cutting the Detectable Warning Surface Panels.

3.3 INSTALLATION

- A. Contractor will not be allowed to install HB-CIP panels until all submittals have been reviewed and approved by the Engineer. Panels shall be installed per manufacturer's instructions.
- B. To the maximum extent possible, the panels shall be oriented such that the rows of in-line truncated domes are parallel with the direction of the ramp. When multiple panels regardless of size are used, the truncated domes shall be aligned between the panels and throughout the entire tactile warning surface installation.
- C. In accordance with the Proposed Accessibility Guidelines for Pedestrian Facilities in the Public Rights of Way 2011, panels shall be located relative to the curb line as shown within Sections 304 and 305 of the Guidelines.
- D. HB-CIP panels shall be tamped or vibrated into the fresh concrete to ensure that there are no voids or air pockets, and the field level of the panel is flush to the adjacent concrete surface or as the Drawings indicate to permit proper water drainage and eliminate tripping hazards between adjacent finishes.
- E. Cutting and Setting of HB-CIP panels shall be cut into size and configuration indicated on the Drawings using a 60 tooth carbide blade on a table saw or equivalent cutting device. Minimize any cantilever effect (to the maximum extent practicable) when cutting between successive embedment ribs as concrete will tend to flow up and over the panels.
- F. The top of the body of the panel shall be fully seated and flush with the adjacent concrete substrate. For specific instructions for cutting and setting refer to Detectable Warning Surface manufacturer's written instructions.

3.4 CLEANING AND PROTECTING

- A. Protect HB-CIP panels against damage during construction period to comply with panel manufacturer's Specifications.
- B. During and after the HB-CIP panel installation and the concrete curing stage, it is imperative that there are no walking, leaning or external forces placed on the panel to rock the panel, causing a void between the underside of the panel and the concrete.
- C. Remove Protective Plastic Sheeting from HB-CIP panel within 24 hours of installation of the panel. Particularly under hot weather conditions (80 degrees or higher), plastic sheeting will adhere strongly (resulting in difficult removal of same) to Detectable Warning Surface panel when not removed quickly.
- D. If requested by the Project Manager, clean HB-CIP panels not more than four (4) days prior to date scheduled for inspection intended to establish date of substantial completion in each area of project. Clean panel by method specified by Detectable Warning Surface panel manufacturer.

END OF SECTION (Updated 10/02/2025)

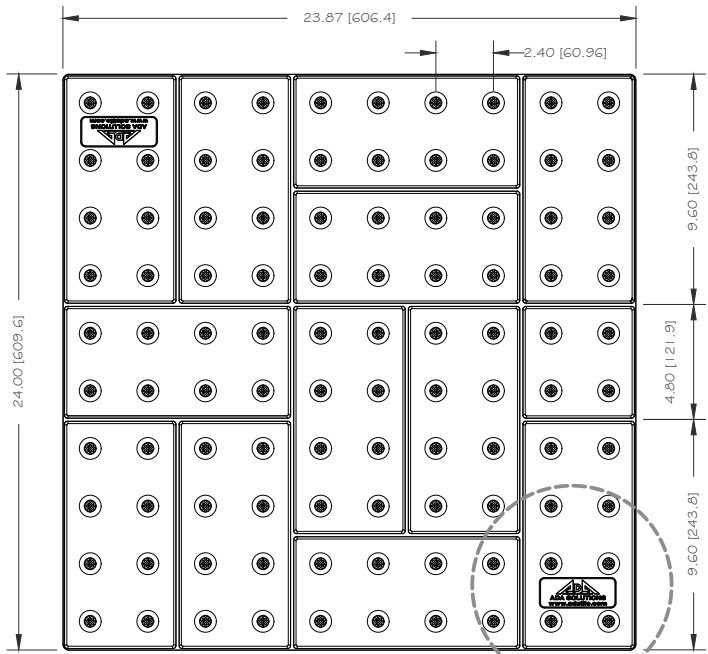

TOP VIEW

AA

A

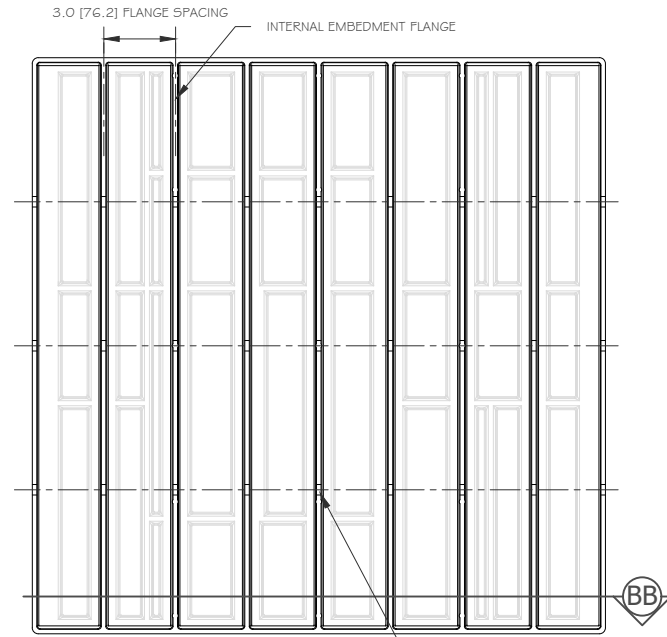

BOTTOM VIEW

BB

0.437" [11.0] DIAMETER HOLES IN EMBEDMENT FLANGE. 3 PER FLANGE.

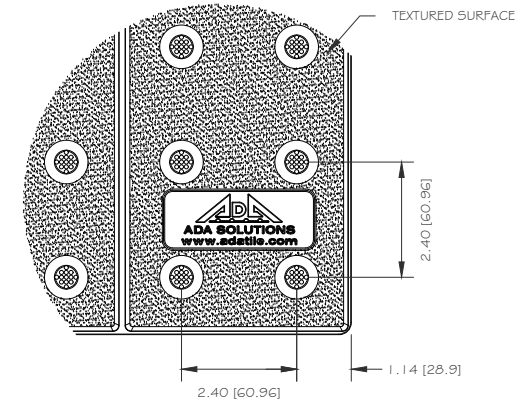

A DETAIL

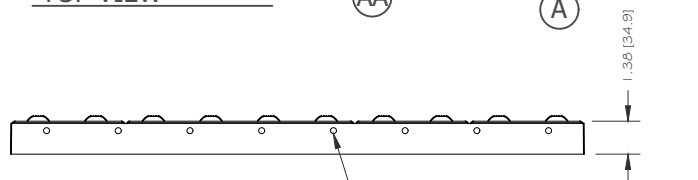

AA END VIEW

0.25" [6.35] DIAMETER VENT HOLES CENTERED BETWEEN EMBEDMENT FLANGES TO ALLOW AIR TO EXIT FROM CAVITIES DURING INSTALLATION INTO UNCURED CONCRETE.

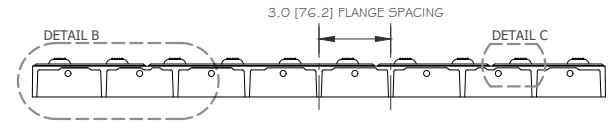

BB SECTION

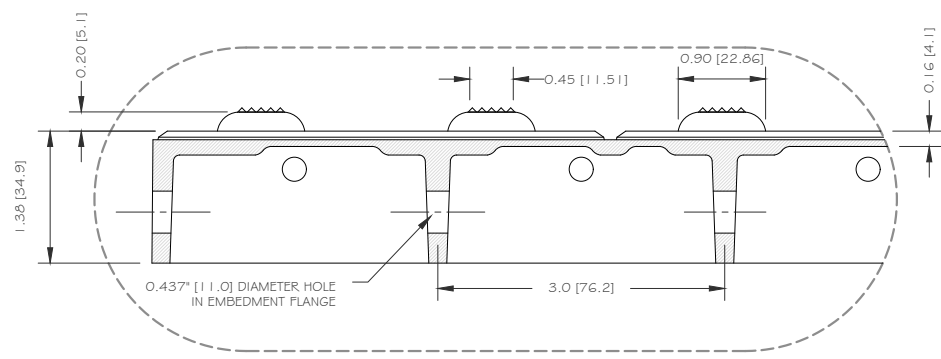

B DETAIL

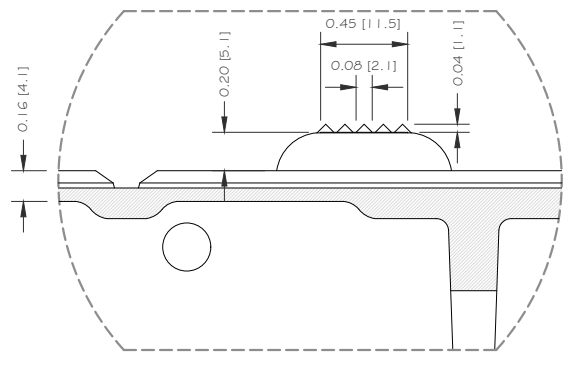

C DETAIL

DETECTABLE WARNING SURFACE PANEL
HERITAGE BRICK PAVER UNIT 24 X 24
 PART SIZE: 24" (609.6 MM) X 23.875" (606.4 MM)
 2.40" (60.96 MM) IN-LINE TRUNCATED DOME SPACING

DIVISION TACTILE WALKING SURFACE INDICATORS		WEBSITE ADATILE.COM
MATERIAL FIBERGLASS REINFORCED POLYMER COMPOSITE SMC		PHONE 1-800-372-0519
DRAWING NUMBER ADA-HBRICK2424_Page 1 of 2	DATE 2021-11-18	DRAWING UNITS INCHES [MM]
		EMAIL INFO@ADATILE.COM



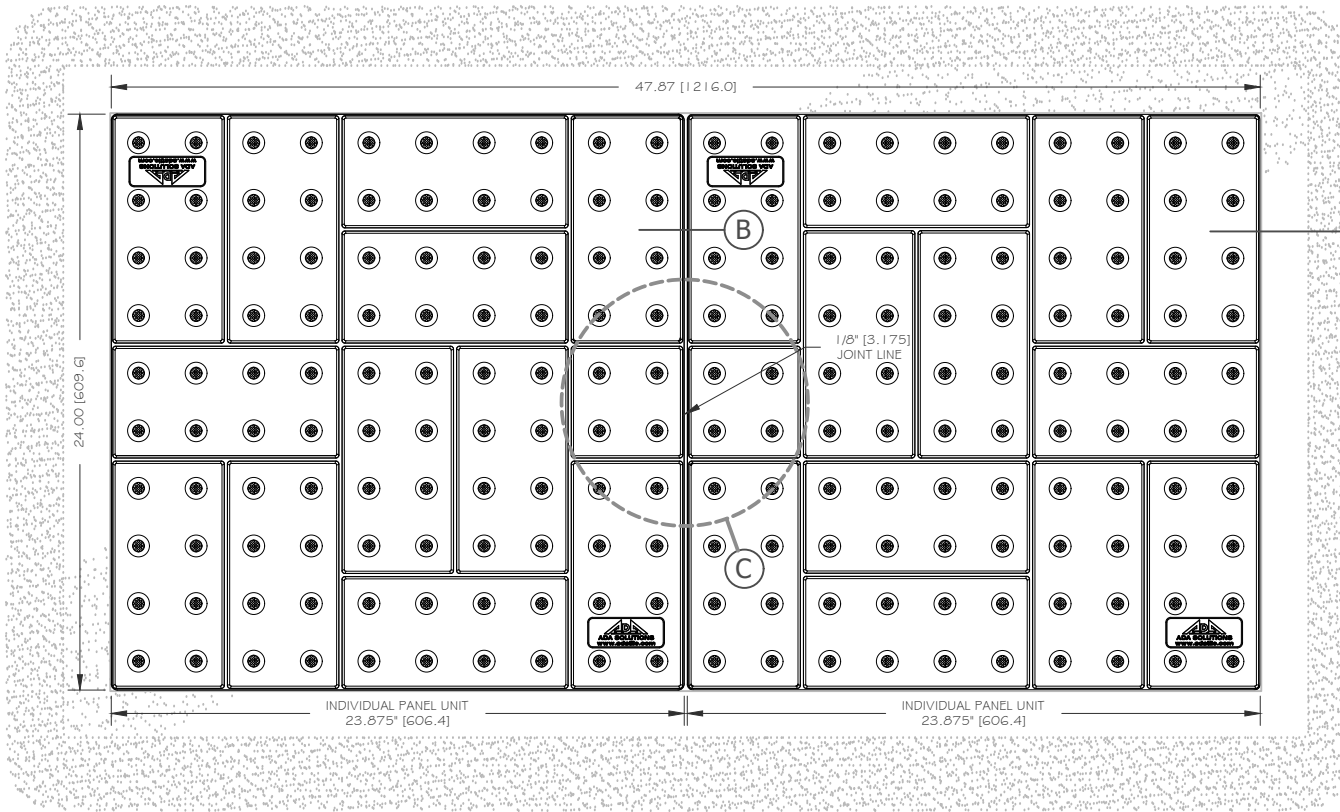

TO MAINTAIN MODIFIED BASKETWEAVE BRICK PATTERN FOR MULTIPLE PANEL INSTALLATIONS, ALIGN PANELS AT HALF-BRICK LOCATION FOUND ON EACH 24x24 PANEL (SHADED BELOW).

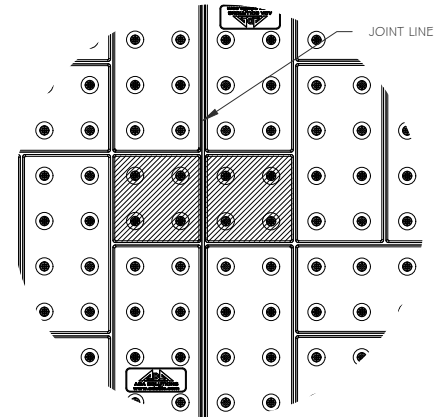

C PATTERN ALIGNMENT

A EMBEDMENT TOP VIEW - 2'x4' LAYOUT

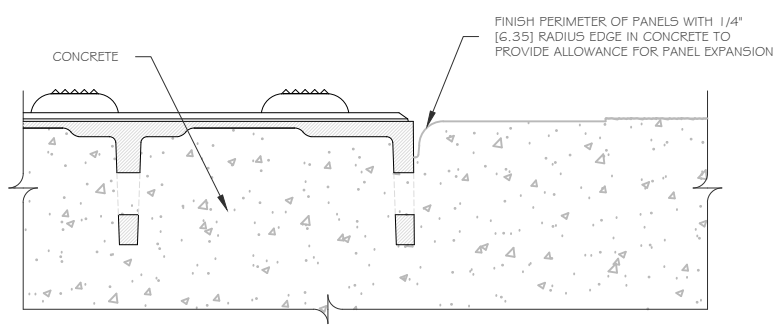

A PERIMETER EMBEDMENT DETAIL

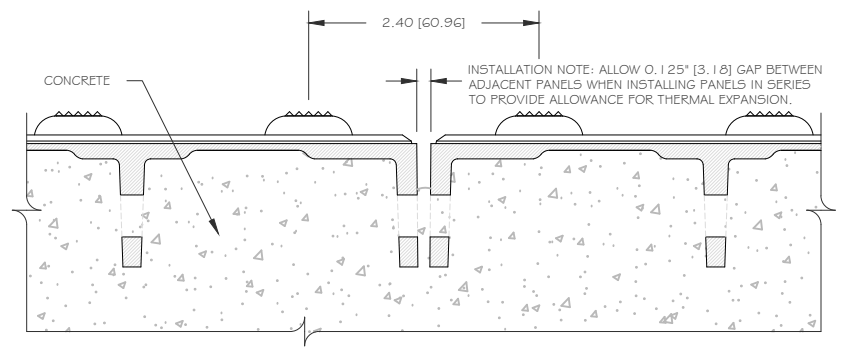

B PANEL-TO-PANEL JOINT DETAIL

DETECTABLE WARNING SURFACE PANEL
HERITAGE BRICK PAVER UNIT 24 X 24
 PART SIZE: 24" (609.6 MM) X 23.875" (606.4 MM)
 2.40" (60.96 MM) IN-LINE TRUNCATED DOME SPACING

DIVISION TACTILE WALKING SURFACE INDICATORS		WEBSITE ADATILE.COM
MATERIAL FIBERGLASS REINFORCED POLYMER COMPOSITE SMC		PHONE 1-800-372-0519
DRAWING NUMBER ADA-HBRICK2424_Page 2 of 2	DATE 2021-11-18	DRAWING UNITS INCHES [MM]
		EMAIL INFO@ADATILE.COM



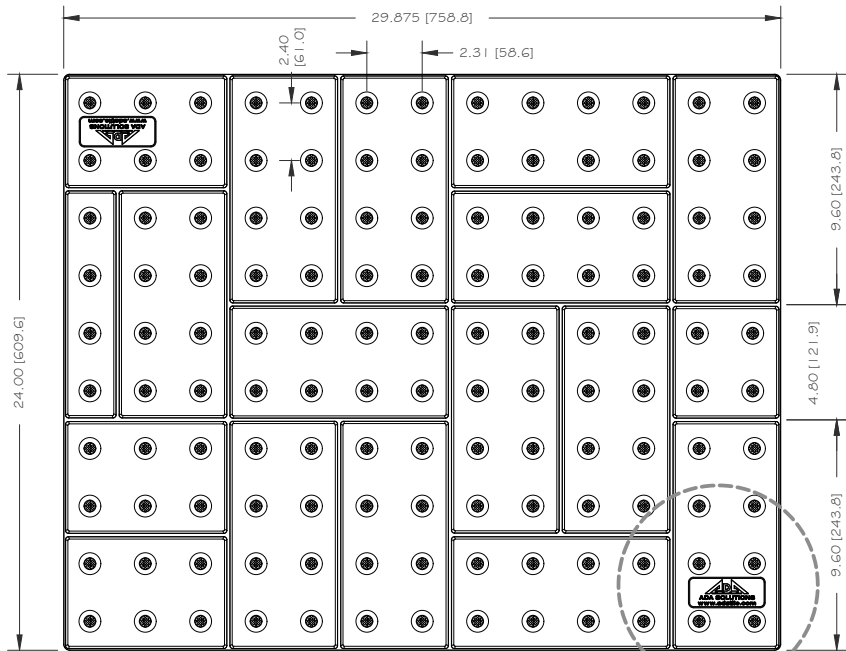

TOP VIEW



AA END VIEW

0.25" [6.35] DIAMETER VENT HOLES CENTERED BETWEEN EMBEDMENT FLANGES TO ALLOW AIR TO EXIT FROM CAVITIES DURING INSTALLATION INTO UNCURED CONCRETE.

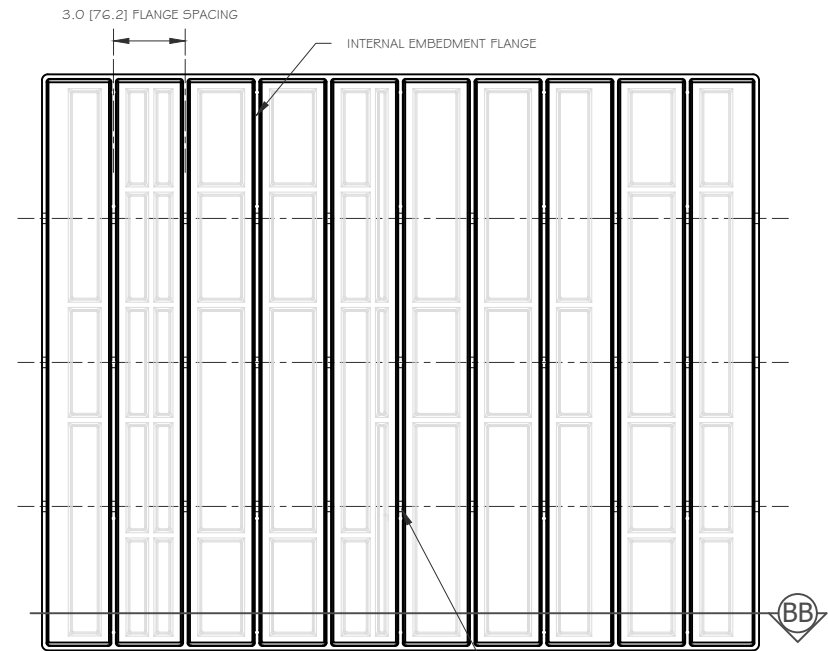

BOTTOM VIEW



0.437" [11.0] DIAMETER HOLES IN EMBEDMENT FLANGE, 3 PER FLANGE.

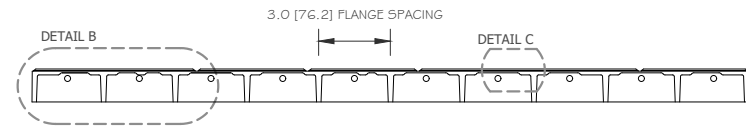

BB SECTION

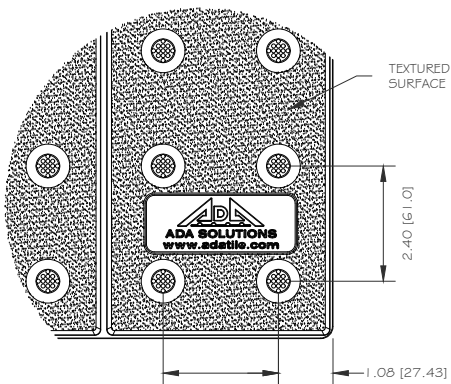

A DETAIL

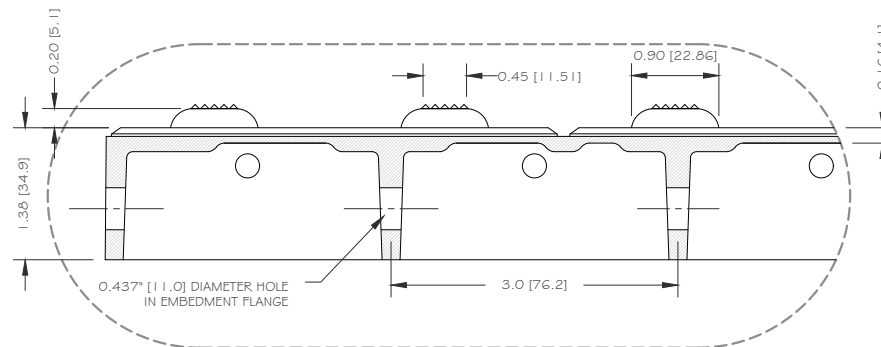

B DETAIL

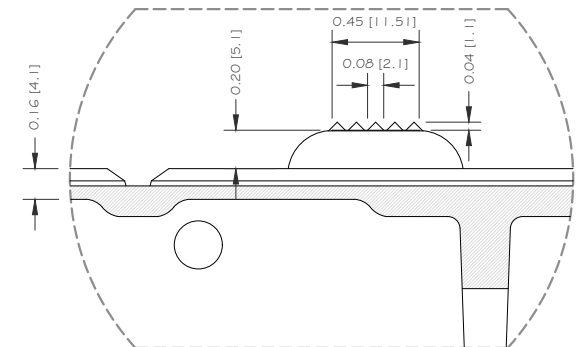

C DETAIL

DETECTABLE WARNING SURFACE PANEL
HERITAGE BRICK PAVER UNIT 24 X 30
 PART SIZE: 24" (609.6 MM) X 29.875" (758.82 MM)
 2.31" (58.67 MM) IN-LINE TRUNCATED DOME SPACING (ALONG 30 INCH LENGTH)

DIVISION
 TACTILE WALKING SURFACE INDICATORS
 MATERIAL
 FIBERGLASS REINFORCED POLYMER COMPOSITE SMC
 DRAWING NUMBER
 ADA-HBRICK2430_Page 1 of 2

DATE
 2021-11-18
 DRAWING UNITS
 INCHES [MM]

WEBSITE
 ADATILE.COM
 PHONE
 1-800-372-0519
 EMAIL
 INFO@ADATILE.COM



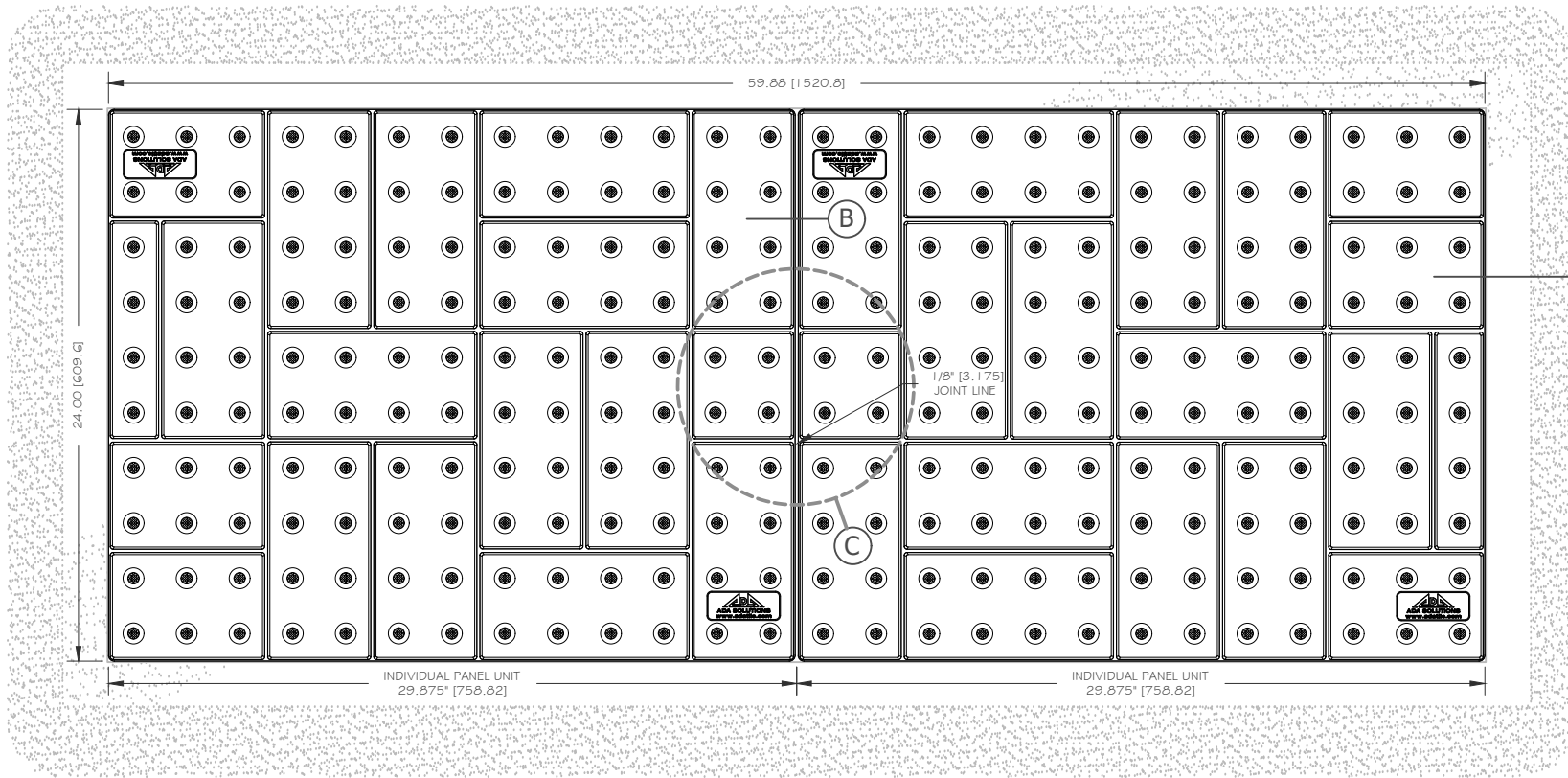

TO MAINTAIN MODIFIED BASKETWEAVE BRICK PATTERN FOR MULTIPLE PANEL INSTALLATIONS, ALIGN PANELS AT HALF-BRICK LOCATION FOUND ON EACH 24x30 PANEL (SHADED BELOW).

EMBEDMENT TOP VIEW - 2'x5' LAYOUT

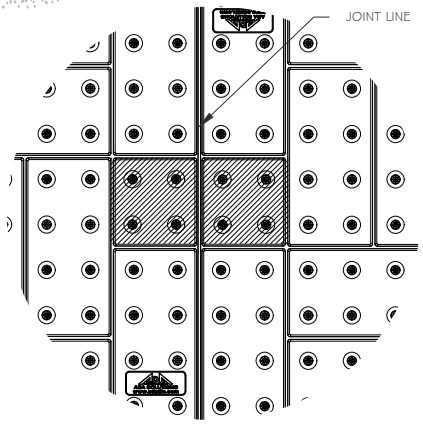
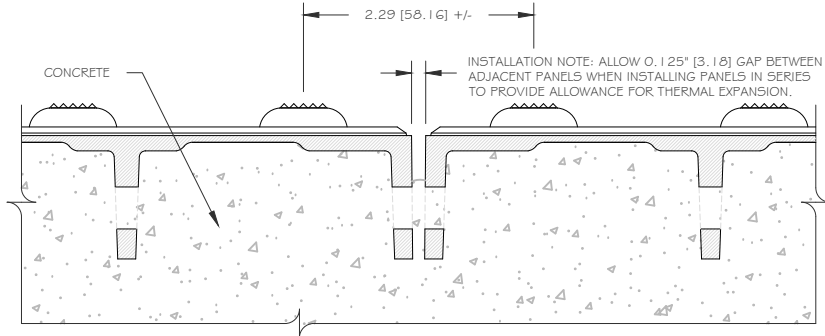
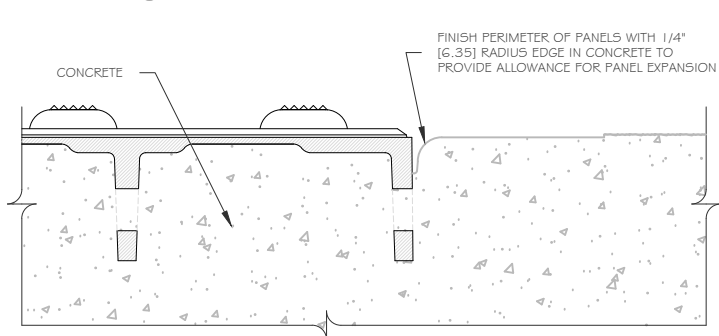

A PERIMETER EMBEDMENT DETAIL

B PANEL-TO-PANEL JOINT DETAIL

C PATTERN ALIGNMENT

DETECTABLE WARNING SURFACE PANEL
HERITAGE BRICK PAVER UNIT 24 X 30
 PART SIZE: 24" (609.6 MM) X 29.875" (758.82 MM)
 2.31" (58.67 MM) IN-LINE TRUNCATED DOME SPACING (ALONG 30 INCH LENGTH)

DIVISION TACTILE WALKING SURFACE INDICATORS		WEBSITE ADATILE.COM
MATERIAL FIBERGLASS REINFORCED POLYMER COMPOSITE SMC		PHONE 1-800-372-0519
DRAWING NUMBER ADA-HBRICK2430_Page 2 of 2	DATE 2021-11-18	DRAWING UNITS INCHES [MM]
		EMAIL INFO@ADATILE.COM



Heritage Brick Cast-In-Place Installation

Installation Procedure

(WET-SET)

Be sure to read and understand all of these instructions before you begin.

- A.** The physical characteristics of the concrete shall be as specified in the contract documents while maintaining a slump range of 4-7 to permit the solid placement of the Tactile Unit in the wet cement.
- B.** The concrete shall be poured and finished level, true and smooth to the required dimensions prior to the placement of the Tactile Unit.
- C.** Place the Tactile Unit 6-8 inches from the curb line. Working in a grid pattern, tamp the Tactile Unit into the wet concrete using a rubber mallet and a piece of wood. Continue this process until all of the air has been released, and the Tactile Unit surface is flush with the surrounding area. **IMPORTANT: Avoid striking the surface of the Tactile Unit directly.**
- D.** Following the placement, the Tactile Unit elevation should be checked to the adjacent surface with a straight edge. The Tactile Unit elevation should be consistent with the contract drawings and specifications. Any required adjustments must be made prior to the time when the concrete begins to set.
- E.** **IMPORTANT NOTICE TO INSTALLER:** To allow for expansion and contraction, after tile is installed, use a 1/4" finish edge trowel around entire perimeter. On a continuous run, be sure to space each unit 1/8" apart.
- F.** When you are confident that the Tactile Unit is in place, and no further adjustments are needed, place a cinder block on both ends to hold the Tactile Unit in place while the concrete sets.
- G.** During and after the Tactile Unit installation, as well as the concrete curing stage, no walking or external forces can be placed on the Tactile Unit. The area must be protected from pedestrian traffic until concrete is cured. The Tactile Warning Surface will be ready for pedestrian traffic within 2-4 hours.
- H.** Be sure to remove plastic protective covering from the face of the Tactile Unit once the concrete is cured.

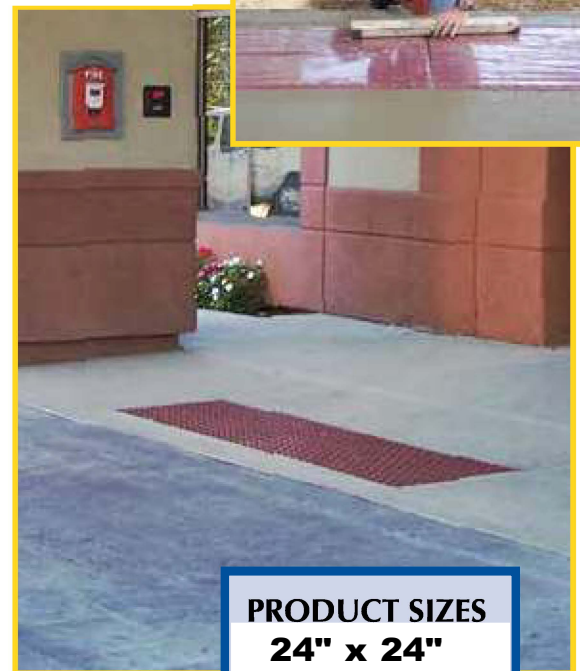

PRODUCT SIZES

24" x 24"

24" x 30"

Use an appropriate sized Tactile Unit to fit the requirement. If cutting is required, contact manufacturer for more details.

View additional photos, drawings and specifications on our website: www.adatile.com

Please call (800) 372-0519 with any questions.



7 Year Product Warranty

Tactile Walking Surface Indicators Fiberglass Reinforced Polymer Composite

ADA SOLUTIONS warrants to the Project Owner and Project Purchaser that the Tactile Walking Surface Indicators (TWSI) product supplied by ADA Solutions is free from defects in workmanship and material including deformation, discoloration, severe fading, and breakage for a period of Seven (7) Years from the date of acceptance of the Project. The warranty is valid only upon completion of the installation, proper maintenance of the TWSI product, and payment in full to ADA Solutions. Warranty becomes effective 24 hours after the date of installation

EXCLUSIVE REMEDIES: ADA Solutions, at its cost, will repair or replace any defective material promptly reported during the warranty period to ADA Solutions. This warranty includes labor costs and the cost of removal of the TWSI product(s). Repair or replacements will be done on site.

All TWSI products manufactured by ADA Solutions are hereby warranted to comply fully with all applicable American with Disabilities Act of 1992 and the Public Rights of Way Accessibility Guidelines (PROWAG), and California Title 24.

WARRANTY LIMITATIONS: ADA Solutions warranty does not apply to conditions resulting from improper use, improper installation, external causes, acts of God, intentional misuse or abuse, neglected or improper annual maintenance, vandalism, modifications to the TWSI product, with the exception of the Owner's right to immediately eliminate an unsafe condition.

DISCLAIMER OF WARRANTY: The above warranty is the Owner's and Purchaser's exclusive warranty. No other warranty expressed or implied shall apply. ADA Solutions specifically makes no warranty of merchantability and/or fitness for a particular purpose. (In no event will ADA Solutions be liable for any damages, lost profit, consequential or economic damages).

Issued Date: **01/01/2023**

Issued to: **Concrete Company
124 Main Street
Salt Lake City, UT 84111**

Project: **Washington School
Salt Lake City, UT 84119**

Owner: **Washington School District
Salt Lake City, UT 84111**

Manufacturer: **ADA SOLUTIONS, a Division of SureWerx USA, Inc.**

Product: **Cast-In-Place Paver Detectable Warning Panels, Brick Red**

Description: **Fiberglass reinforced polymer composite material, UV stable with homogeneous color**

Issued by:

John Stieby

Name

Director of Business Development

Title

01/01/2023

Date



Certificate of Compliance for Build America, Buy America Act

August 22, 2025

ADA Solutions certifies that within the meaning of the Infrastructure Investment and Jobs Act ("IIJA"), Pub. L. No. 117-58, which includes the Build America, Buy America Act ("the Act"). Pub. L. No. 117-58, §§ 70901-52, the products identified below are all manufactured in the United States and greater than 55 percent of the cost of components is sourced domestically:

- ADA Solutions polymer composite detectable warning surface panels
- ADA Solutions polymer composite directional wayfinding panels
- ADA Solutions Iron Dome cast iron detectable warning surface plates

Additionally, the products identified above qualify under The Buy American requirements (23 CFR 635.410 and 2 CFR Part 184) which require that all steel and manufactured goods be produced in the United States.

Sincerely,

A handwritten signature in black ink, appearing to read 'John Stieby', with a long horizontal flourish extending to the right.

John Stieby
Director of End User Sales and Product Development