

# Operation MANUAL

## JEH Series Electric Chain Hoists

Prod. No. 107500  
Mod. No. JEH18

Prod. No. 107501  
Mod. No. JEH14



## TABLE OF CONTENTS

Warranty and Service .....	2	Inspecting the Load Chain .....	7
Warnings .....	3	Inspecting the Hooks .....	7
Introduction .....	4	Operating the Hoist .....	8
Description .....	4	Maintenance .....	9
Specifications .....	4	Brake inspection .....	9
Unpacking .....	5	Lubrication .....	9
Contents of the Shipping Container .....	5	Replacing Load Chain .....	9
Installation and Assembly .....	5	Inspection and Maintenance .....	11
Grounding Instructions .....	5	Troubleshooting .....	12
Extension Cords .....	5	Electrical Connections .....	13
Installing Chain Container .....	6	Parts Breakdown .....	14
Pre-Operation Inspection .....	7	Replacement Parts .....	15

## WARRANTY POLICY

JET EQUIPMENT AND TOOLS LTD. (JET®) makes every effort to ensure its products are manufactured to the highest standards and are guaranteed against defects in materials and workmanship when the product is used for the purpose for which it was designed.

This guarantee applies only to JET products purchased new from a JET authorized distributor.

JET product warranties are extended to the original retail purchaser only. This warranty does not apply to any product showing signs of abuse, misuse, alteration, or having been improperly maintained or repaired.

This warranty does not cover damage attributable to normal wear and tear.

Any JET product that fails during normal use and is within the specified warranty period for that product will be repaired or replaced at JET's discretion. Repairs and/or replacements are warranted as described for the specific product and only for the remainder of the original warranty period.

Repair or replacement is the exclusive remedy for defective product under this warranty.

Warranty is expressly in lieu of all other warranties, including the implied warranty of merchantability or any implied warranty of fitness for a particular application.

Any JET product for which there is a warranty claim should be returned PREPAID to an authorized JET distributor or service centre. Authorized Warranty Depots are found at [surewerx.com](http://surewerx.com)

ALL warranty claims must be accompanied by proof of purchase and an explanation of the defect or failure. It is the customer's responsibility to provide this information.

JET shall not be held liable for any consequential or incidental damages for breach of any expressed or implied warranty on their products. No claims for damages of any type will be considered and all products are sold with this understanding.

Any costs incurred to obtain warranty consideration or services are the Customer's responsibility including shipping and handling, travel, lost time, or lost production.

## SPECIFIED WARRANTY — MATERIAL HANDLING

### 1 Year Limited Warranty

Chain Hoists Hand Cable Pullers  
 Air Hoists Lever Chain Pullers  
 Electric Hoists Grip Pullers  
 Electric Trolleys Manual Adjustable Trolleys  
 Drum Clamps Beam Clamps  
 Plate Clamps Blocks and Sheaves  
 Pallet Trucks Mobile Lift Tables  
 Winches

## GENERAL INFORMATION ON JET CHAIN HOISTS AND PULLERS

**Customs Lifts** — Custom lift lengths are available, however, custom lift hoists and pullers are NOT returnable.

**CAUTION:** Be sure that supporting structures and load-attaching devices used in conjunction with hoists, provide an adequate safety factor to handle the rated load plus the weight of the equipment. If in doubt, consult a qualified structural engineer.

This equipment is not to be used for lifting, supporting, or transporting people, or lifting, supporting, or transporting loads over people.

**IMPORTANT:** Before installation and operation, see maintenance and operations manual for additional warnings, precautions and operating instructions.

**NOTE:** Batteries supplied with certain products may have been subjected to long shelf life, resulting in low energy or a dead battery. Please source replacement batteries locally. Please follow instructions in the manuals for products using rechargeable batteries. Dead batteries do not constitute a warranty claim.

## WARNINGS

1. Read and understand the entire owner's manual before attempting assembly or operation.
2. Read and understand the warnings posted on the machine and in this manual. Failure to comply with all of these warnings may cause serious injury.
3. Replace the warning labels if they become obscured or removed.
4. This chain hoist is designed and intended for use by properly trained and experienced personnel only. If you are not familiar with the proper and safe operation of a chain hoist, do not use until proper training and knowledge have been obtained.
5. Do not use this chain hoist for other than its intended use. If used for other purposes, JET disclaims any real or implied warranty and holds itself harmless from any injury that may result from that use.
6. Do not install this chain hoist where explosive hazards may exist.
7. Give your work undivided attention. Looking around, carrying on a conversation and "horse-play" are careless acts that can result in serious injury.
8. Do not use to lift people or loads over people. Warn others in the vicinity when lifting or transporting a load. Avoid swinging load and hook.
9. Do not exceed the rated capacity of the chain hoist.
10. Make sure limit switches are operating properly. Do not use limit switches as routine operating stops; they are emergency devices only.
11. Do not use the load chain as a sling; this may cause damage to the chain.
12. Maintain firm footing when operating the hoist.
13. Always inspect the chain hoist for damage prior to use. Do not use a chain hoist with twisted, kinked, worn or otherwise, damaged chain. If the chain hoist is damaged, do not use until it has been repaired or replaced.
14. Do not use more than one chain hoist to lift or move a load. If this is unavoidable, each chain hoist must have the same capacity as the load to be moved.
15. Never allow the load chain to "set" over sharp edges. All lifts must be made with straight chain that is free of obstacles.
16. Do not use a chain hoist unless load is centered between top and bottom hooks.
17. Protect load chain from weld splatter and other contaminants. Do not allow the hook or chain to be contacted by a live welding electrode.
18. Always take time to study the job to be performed and choose the safest method. Do not place yourself or other people in an unsafe position.
19. Leave all internal maintenance to a qualified JET service centre.
20. Replace the chain with factory replacement chain only. Do not use any other type of chain.
21. Never use the chain hoist if either hook is stretched, deformed, or has a broken or missing safety latch. Always replace the safety latch and/or the hook before placing the chain hoist back into service.
22. Do not operate this hoist while tired or under the influence of drugs, alcohol, or any medication.
23. Understand and follow all procedures as set forth in American National Standards titled "Performance Standard for Electric Chain Hoists." ANSI/ASME HST-1. This standard is available through the American Society of Mechanical Engineers, [www.asme.org](http://www.asme.org).
24. Do not use in wet, damp or poorly lit locations. This hoist is not rated for outdoor use.
25. CALIFORNIA PROPOSITION 65 WARNING: This product may contain chemicals known to the State of California to cause cancer, or birth defects or other reproductive harm.

**Familiarize yourself with the following safety notices used in this manual:**

**⚠ CAUTION** This means that if precautions are not heeded, it may result in minor injury and/or possible machine damage.

**⚠ WARNING** This means that if precautions are not heeded, it may result in serious or even fatal injury.

## INTRODUCTION

This manual is provided by JET covering the safe operation and maintenance procedures for a JET Electric Chain Hoist. This manual contains instructions on installation, safety precautions, general operating procedures, maintenance instructions and parts breakdown. This machine has been designed and constructed to provide consistent, long-term operation if used in accordance with instructions set forth in this manual. If there are any questions or comments, please contact either your local supplier or JET customer service. JET can also be reached at our web site: [surewerx.com](http://surewerx.com)

## DESCRIPTION

JET electric chain hoist models are available in a variety of voltages and lifting and traversing configurations.

**All JET hoists comply with UL/cUL and ANSI/ASME B30.16 and HST-1 standards.**

All chain hoists are available in custom configurations to meet your specifications. Contact your dealer or JET for more information.

**⚠ WARNING** Read and understand the entire contents of this manual before attempting set-up or operation! Failure to comply may cause serious injury.

Record your purchase information here for quick reference:

Model No.:
Stock No.:
Serial No.:
Purchased From:
Date Purchased:
Date Installed:
Installer:

## SPECIFICATIONS

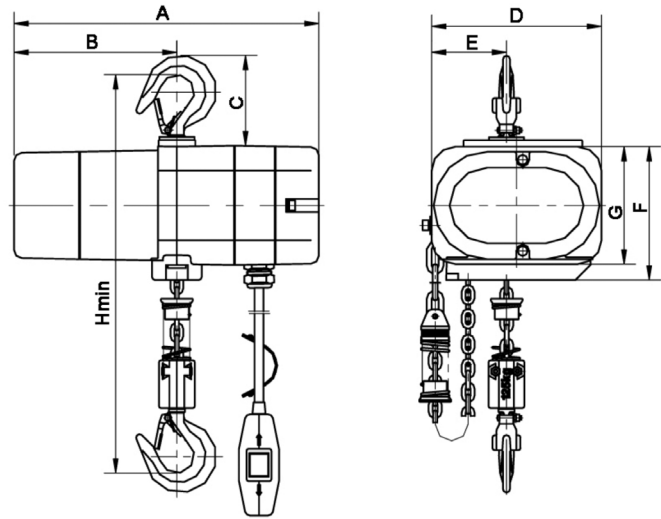

Figure 1

Prod. No.	107500	107501
Rated Capacity (Ton)	1/8	1/4
Standard Lift (ft.)	10	10
Hoisting Speed (fpm)	16	8
Motor	1/6HP, 115V, 1PH, 60Hz	
Rated Amps	3	3
Duty Cycle*	25%	25%
Duty Cycle Rating*	H3	H3
No. of Falls	1	2
Load Chain (mm)	4 Dia. x 12	4 Dia. x 12
Push Button Control Cord Length (ft.)	6	6
Net Weight (lbs.)	30.62	34.6
Shipping Weight (lbs.)	33.48	37.22
A	12.09	12.09
B	6.46	6.46
C	3.58	3.58
D	6.81	6.81
E	2.99	3.74
F	5.47	5.47
G	4.72	4.72
Headroom — H (in.)	15.27	17.1

Table 1

\*25% duty cycle = maximum on time: 15 min/hr.  
maximum number of starts: 150/hr.

The above specifications were current at the time this manual was published, but because of our policy of continuous improvement, JET reserves the right to change specifications at any time and without prior notice, without incurring obligations.

## UNPACKING

Lift the hoist out of the carton by the top hook or the centre section. Do not apply excessive force to the motor cover, as damage may result.

Carefully inspect the hoist for shipping damage, and for loose or missing parts. Report any damage immediately to your distributor and shipping agent. Do not discard any shipping material until the Hoist is installed and running properly.

### Contents of Shipping Container

- 1 Electric Chain Hoist
- 1 Chain Container with Bracket and Fasteners
- 1 Power Cord
- 1 Pendant Cord
- 1 Owner's Manual
- 1 Load Test Certificate

## INSTALLATION & ASSEMBLY

Support for the hoist may be hook, clevis pin, trolley, or beam clamp. Supporting structures (such as I-beams, etc.) should be installed by properly licensed professional installers.

**CAUTION** Whatever method of suspension is chosen, the support components must be rated equal to or greater than the capacity of the chain hoist.

### Electrical Connections

**WARNING** Electrical connections must be made by a qualified electrician in compliance with all relevant codes. This machine must be properly grounded to help prevent electrical shock and possible fatal injury.

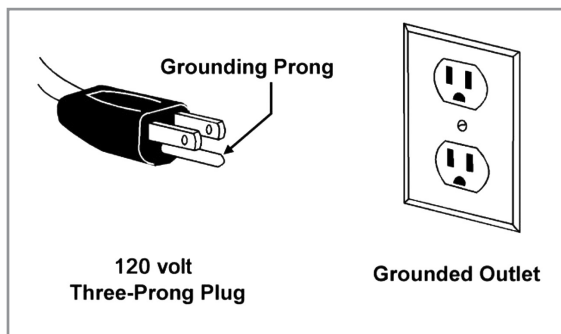

Figure 2

This machine's power cable is installed with a plug that has an equipment-grounding conductor and a grounding prong, similar to that shown in Figure 2. The plug must be plugged into a matching outlet that is properly installed and grounded in accordance with all local codes and ordinances. Do not modify the plug — if it will not fit the outlet, have the proper outlet installed by a qualified electrician.

### Grounding Instructions

This machine must be grounded. In the event of a malfunction or breakdown, grounding provides a path of least resistance for electric current to reduce the risk of electric shock.

Improper connection of the equipment-grounding conductor can result in a risk of electric shock. The conductor with insulation having an outer surface that is green with or without yellow stripes is the equipment-grounding conductor. If repair or replacement of the electric cord or plug is necessary, do not connect the equipment-grounding conductor to a live terminal.

Check with qualified electrician or service personnel if the grounding instructions are not completely understood, or if in doubt as to whether the tool is properly grounded.

Repair or replace a damaged or worn cord immediately.

Make sure the voltage of your power supply matches the specifications on the nameplate of the hoist.

### Extension Cords

If an extension cord is necessary, make sure the cord rating is suitable for the amperage listed on the hoist's nameplate. An undersized cord will cause a drop in line voltage resulting in loss of power and overheating.

Use Table 2 as a general guide in choosing the correct size cord. If in doubt, use the next heavier gauge. The smaller the gauge number, the heavier the cord.

### Recommended Gauges (AWG) of Extension Cords

Amps	Extension Cord Length*					
	25 ft	50 ft	75 ft	100 ft	150 ft	200 ft
< 5	16	16	16	14	12	12
5 to 8	16	16	14	12	10	NR
8 to 12	14	14	12	10	NR	NR
12 to 15	12	12	10	10	NR	NR
15 to 20	10	10	10	NR	NR	NR
21 to 30	10	NR	NR	NR	NR	NR

Table 2

\*Based on limiting the line voltage drop to 5V at 150% of the rated amperes.

NR: Not Recommended.

## Installing Chain Container

Your hoist is supplied with a canvas chain container (Figure 3) designed to fit the particular length of chain. If a different length chain is ever installed on this hoist, the chain container must be replaced by one of proper size.

**⚠ WARNING** Do not overfill chain container. If chain should overfill and begin to fall, the entire chain container may empty without warning, resulting in serious personal injury or property damage.

To assemble the chain container to the hoist:

1. Hang hoist in position on the I-Beam or trolley. Do not install chain container yet. Allow slack side and load side of chain to hang freely from hoist.
2. Apply power to the hoist and press the DOWN button until the lower limit switch is tripped.
3. Check the chain container to ensure that the seam is inside the bag. The bag must not be inside out.
4. Insert bracket prongs into interior bag slots (Figure 3) as far as they will go.
5. Push the bracket down into the bag, making sure the flaps are raised (Figure 4).
6. Push the flaps over and down until they are secure (Figure 5).
7. Remove the screw and washer holding the end chain to the hoist (Figure 6). Mount the bracket of the chain container in that location as shown in Figure 7.
8. Put the chain stop into the container (Figure 7) and operate the hoist to bring the load hook up until the upper limit switch is tripped.
9. Check the chain to ensure that all the non-loaded chain is completely in the container.

**⚠ CAUTION** Do not put chain into the chain container by hand! By not following the above steps, the chain can become twisted or kinked and can damage the hoist.



Figure 3



Figure 4



Figure 5

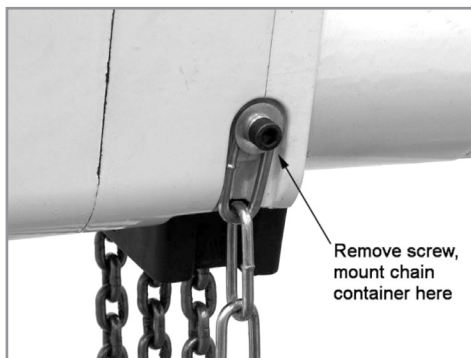

Figure 6

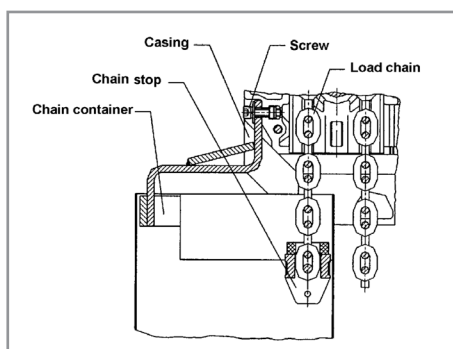

Figure 7

## PRE-OPERATION INSPECTION

### Limit Switch Inspection

1. Press UP button.
2. While the hook moves up, raise the limit switch paddle where the chain enters the hoist.
3. Hook should immediately stop.
4. Check DOWN limit switch in similar manner.

### Inspecting the Load Chain

Clean the chain with a solvent, and carefully inspect the entire load chain. The chain should be visually checked before each day's use. Replace damaged chain before using the chain hoist.

Replace the load chain if any of the following are identified:

1. Seriously rusted or cracked.
2. Marks on the chain surface are deeper than 5% of the link's diameter.
3. Links are twisted or deformed.
4. The links are stretched too long or seriously worn on the surface, especially at the points where links contact each other. To check the links for stretch, proceed as follows:

5. Select an unworn, unstretched length of chain (at the slack end for example). Let the chain hang vertically with a light load (about 20 pounds) on the chain to pull it taut.
6. Use a large caliper to measure the outside length of a convenient number of links. Measure the same number of links in a used section of chain and calculate the percentage increase in length of the worn chain.
7. If the length of the worn chain is more than 1-1/2% longer than the unused chain, then the chain should be replaced. If the chain is worn less than 1-1/2%, check it at several more places along its length. If any section is worn more than 1-1/2%, the chain should be replaced.

Never extend load chain by welding a second piece to the original.

**⚠ WARNING** Do not operate the hoist with a twisted, kinked, or damaged load chain. Do not splice the load chain.

Check that the chain does not twist along its length from hoist to hook. If a twist is present on units with multiple falls, the hook must be passed back through the chain loop to remove all twists in the chain.

**⚠ WARNING** The load chain supplied with your JET chain hoist is designed, manufactured, and tested for proper fit and durability. Over a period of time the chain may need to be replaced. For your own safety, use factory replacement chain only. Use of other than factory replacement chain may cause serious injury and/or damage to the hoist.

### Inspecting the Hooks

It is important to check top and bottom hooks for proper opening and other signs of deformation or damage. Replace a hook immediately if any of the following problems are identified:

1. The safety latch no longer contacts the hook opening.
2. The vertical angle at the neck of the hook reaches 10° (see Figure 8).
3. Chemical corrosion or cracks on the hook.
4. Excessive wear on the inside surface.
5. The throat opening has enlarged wider than the maximum permissible 10% increase, as shown in Figure 9.

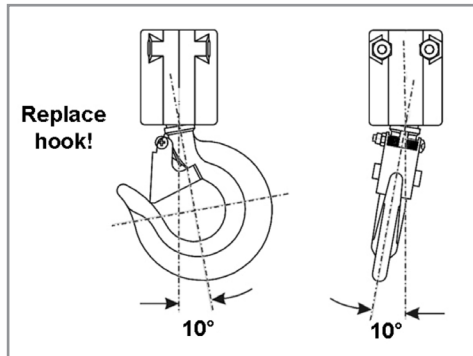
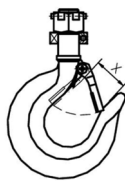

Figure 8



HOIST CAPACITY	TOP HOOK and BOTTOM HOOK	
	X-Normal	X-Limit
1/8 Ton	<b>0.906 inch</b>	<b>1 inch</b>
1/4 Ton	<b>0.906 inch</b>	<b>1 inch</b>

NOTE: Maximum permissible throat opening of hook with latch fully retracted.

Figure 9

**NOTE:** Excessive hook throat opening or twist indicates abuse or overloading of the hoist. If such deformation is discovered, inspect hoist, chain, and all supporting members very carefully for additional indications of excessive hoist loading.

**⚠ WARNING** Do not attempt repair of a hook by heat treating, bending, or attaching anything by welding. Such procedures will weaken and may cause failure of the hook.

## OPERATING THE HOIST

**⚠ CAUTION** Before beginning a work shift, an operator should test the pushbutton station, limit switches and brake control. If not functioning properly, they should be replaced or repaired before putting hoist in service.

Allow the hoist to come to a full stop before changing direction. Rapidly reversing or catching a falling load can overload the hoist system and cause a failure in the hoist and/or chain, resulting in injury or property damage.

If the hoist is connected to a manual trolley, move the hoist by pushing on the suspended load. Move an unloaded hoist by pulling on the empty hook. Do **NOT** move the hoist by pulling on the pendant cord.

The brake mechanism must be kept clean and free from dirt, water, and oil. Never allow oil to penetrate the brake mechanism. Always keep your hoist clean, and store in a clean, dry location.

Follow this general procedure for hoisting loads:

1. Secure the upper hook to the supporting structure.
2. Place load sling or chain in the centre of the bottom hook, making sure the safety latch is secure.

**Never load the hook in front of the safety latch.** See Figure 10.

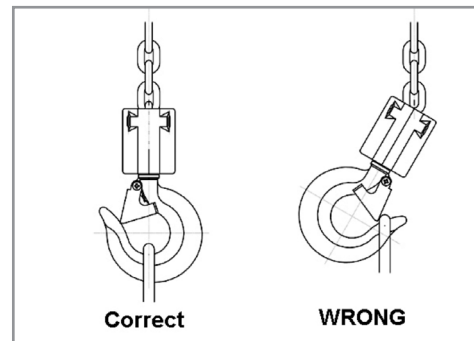

Figure 10

3. Avoid lifting one load with two hoists. If this is unavoidable, apply equal weight to both hoists and use hoists with the proper lift capacity. **Capacity of each hoist must be equal to the total load to be lifted.**
4. Press the UP button and remove all slack in load chain. Increase tension in the load chain until the hoist is about to raise the load.
5. Check again that the load is properly slung, directly under the hoist, and will not suddenly swing or twist.
6. Raise the load an inch or two above the ground and stop. Observe load for a few moments, looking for signs that the load or hoist system is unstable, or other indications that there is a problem.
7. Check that the chain is not twisted at the bottom hook. All welds should face the same direction (see Figure 14). For hoists with two or more falls of chain, make sure the bottom hook is not turned over. This may cause the chain to twist.
8. Raise load to the travelling height. Raise only to the height necessary to safely clear all obstacles.
9. Lower load at destination. If both UP and DOWN commands must be used during lowering, pause for a moment between each reversal of load direction.
10. Slowly allow weight to shift from hoist to ground or new support. Do not approach load until all tension is out of chain and load is stable.

## MAINTENANCE

### Brake Inspection

**CAUTION** Keep brake surface and lining free of grease.

1. Remove load and disconnect hoist from the power source.
2. Remove the back frame cover (index #31, page 15).
3. Check for worn brake disc by measuring the brake air gap with a feeler gauge (Figure 11). A brake gap larger than the allowable wear limit — 0.039" — may cause chatter or failure to release.
4. If the brake is not operating properly, the **entire brake assembly** must be replaced by qualified service personnel.

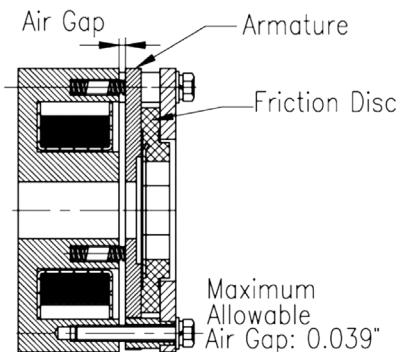

Figure 11

### Lubrication

The gear housing has been filled with 1/2 pound of grease at the manufacturer and should not require attention. If future lubrication becomes necessary, use approximately 3/4 cup of a light semi-fluid NLGI #1 grease.

Wipe the chain clean with a cloth periodically and apply a light coat of SAE 90 gear oil.

### Replacing Load Chain

Over time, the load chain will wear or elongate. This can cause damage to the hoist, breakage, or non-engagement of the load sheave. The following procedures describe replacing the load chain for single and multiple fall hoists. **These procedures should be performed by experienced personnel only.**

### How to Cut Chains

Use a bolt cutter with special cutter jaws for cutting hardened chain. Cut only one side of the link at a time. When making the second cut, place a mat over the chain to catch the flying chain section.

### Making a C-Link

Replacing load chain will require the use of a C-link (in some cases, two C-links), which you can easily make as follows:

1. Cut a link from the old chain.
2. Cut the weld from the link leaving an opening approximately 1.25 times the diameter of the link material. See Figure 12.
3. Grind the cut areas smooth and remove all burrs.

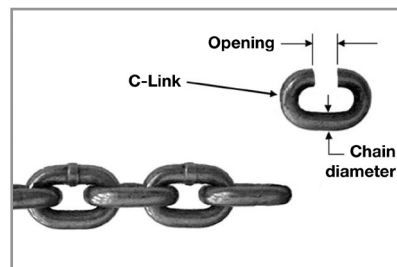

Figure 12

### Single Fall Chain Hoist

1. Lower the load hook until only 1 to 2 feet of slack chain remains in the chain container.
2. Remove chain container.
3. On the slack side of the old chain, remove the chain stop and the spring (Figure 13). Keep these handy for later re-installing.

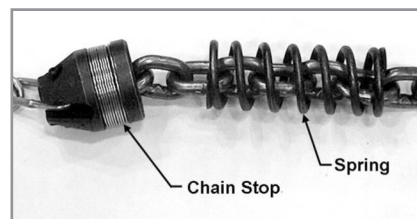

Figure 13

4. Using a C-link, connect the new chain to the old chain. Be sure vertical link welds face away from load sprocket (see Figure 14).

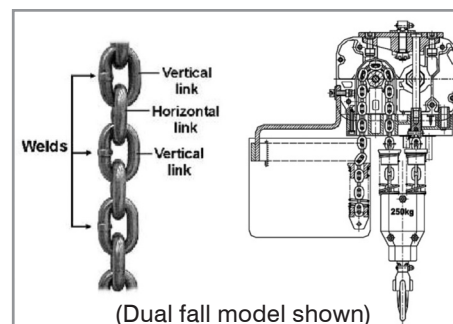

Figure 14

5. Keep tension on both sides of the chain and lower the load hook to pull the new chain through the hoist. Do not let the chain twist or bind as it is being pulled through the hoist.
6. Stop hoist when 1 to 2 feet of the new chain remains on the slack side.
7. Install the spring and chain stop on the slack end of the new chain.
8. Remove C-link. Remove the load hook and the spring from the old chain and install them on the new chain. Inspect the condition of both spring and hook.
9. Lower load hook until the limit switch stops hoist movement. Inspect the chain for any signs of twist.
10. Install chain container following the instructions in this manual. Do not fill chain container by hand.
11. It is recommended that after installing new chain, the first few lifts be limited to no more than 25-50% of the rated load. Thoroughly inspect chain for twist before placing hoist in routine service.

### Vertical and Horizontal Links

Vertical and horizontal are determined from the relationship with the load sprocket. Vertical links will be guided by the centre slit in the load sprocket. Horizontal links will engage in the oval pockets on the sprocket. See Figure 15.

### Dual Fall Chain Hoists

**CAUTION** The link on the load side end must be a vertical link. If it is a horizontal link, the chain will have a twist in it.

1. Lower hook until only 1 to 2 feet of slack chain remains in the chain container.
2. Remove chain container.
3. On the slack side of the chain, remove chain stop, and remove the spring(s). (See Figure 13). Keep these handy for later re-installing.
4. Using a C-link(s), connect the new chain to the old chain. If the end link of the old chain is horizontal, use two C-links. If the end link of the old chain is vertical, use one C-link See Figure 15. Using the correct number of C-links will properly orient the chain and ensure that the first link on the load-side end is a horizontal link.
5. Install the spring(s) and chain stop on the opposite end of the new chain.
6. Support the load hook so that the load chain can pass through the chain sheaves smoothly.

7. Press the DOWN button to move the chain through the hoist. Keep tension on the chain as you pull it through to the load side until the C-link(s) clears the hoist at the load side.
8. Feed the new chain through the load hook.
9. Remove the clevis pin from the suspension block (#48, page 15), and remove old chain.
10. Remove C-link and connect the end of the new chain to the suspension block, using the clevis pin and a new cotter pin to secure it. **Do not substitute any other pin or bolt in this application.**  
NOTE: Be sure that there is no twisting of the chain between the last chain sprocket in the hoist and the suspension block.
11. Install chain container following instructions in this manual. Do not fill the chain container by hand.
12. Lower hook until limit switch stops hoist movement, then raise hook until limit switch stops hoist movement. Inspect chain for any signs of twist and correct before continuing.
13. It is recommended that the first few lifts be limited to no more than 25–50% of the rated load. Inspect chain for twist before placing hoist into routine service.

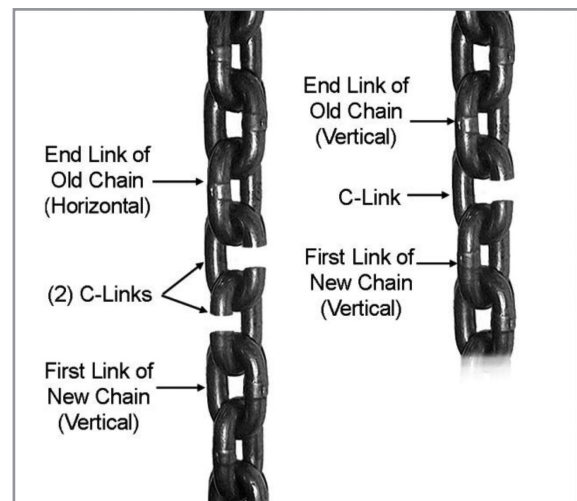

Figure 15

## INSPECTION AND MAINTENANCE

**⚠ WARNING** All repairs and adjustments are to be performed by trained and experienced personnel using procedures that are approved for the hoist system being serviced. All safety-related deficiencies discovered in the inspection are to be corrected before hoist is placed back into service. Check for internal damage whenever external damage has occurred.

Read and follow the ANSI Inspection and Maintenance instructions. Know the meaning of Frequent Inspection, Periodic Inspection, Normal Service, Heavy Service, and Severe Service. It is the customer's responsibility to understand and follow all ANSI and This inspection and maintenance instructions.

The following items are to be inspected by appointed personnel at the time interval noted below. Dated inspection and repair reports must be maintained. Copies of all reports must be available to service personnel.

### Inspection Schedule A

Service Interval:

**Normal Service — Monthly**

**Heavy Service — Weekly to Monthly**

**Severe Service — Daily to Weekly**

1. Check brake for slippage.
2. Check that pushbutton controls operate properly.
3. Check that limit switches function properly. Without load, operate up button control while observing stopper spring. If stopper spring becomes compressed and motor does not stop, STOP operation immediately. The limit switch is not operating properly. Repeat test with down button control.
4. Check top hook and load hook for deformation, chemical damage, and cracks.
5. Check that the load chain is clean and lightly lubricated, free of excessive wear or deformation at the contact points between links and link and hook. This hoist uses a special alloy hoisting chain and does not interchange with any other manufacturer. All replacement chain must be purchased from JET.
6. Check that the chain is untwisted and passes through all sprockets smoothly while under load.
7. Check the entire hoist system for signs of damage and loss of integrity

### Inspection Schedule B

Service Interval:

**Normal Service — Yearly**

**Heavy Service — Semi-Annually**

**Severe Service — Quarterly**

1. Do all the Schedule A items.
2. Check the entire unit for loose screws, bolts, nuts and pins.
3. Check for evidence of excessive wear, corrosion, cracks, or distortion in the following parts: hook parts, chain attachments, suspension bolts and shafts, gears, bearings, pins, rollers, and locking and clamping devices.
4. Check for evidence of damage to hook parts including hook retaining nuts and collars and pins and hook holding frame and parts used to secure the frame.
5. Check for evidence of damage or excessive wear of load gear, sheave, and sprocket wheel. If the pockets are too deep, the chain may jam with a corresponding failure of engagement between chain and sprocket or sheave.
6. Check for evidence of excessive load brake wear. Inspect clearance between brake components and adjust if needed.
7. Check for evidence of pitting or other deterioration of visible controller contacts.
8. Check for evidence of deterioration of supporting structures and trolleys.
9. Check for visible deformation of limit switch coil springs.
10. Check that all warning labels are present and readable.

## TROUBLESHOOTING THE JEH HOIST

Trouble	Probable Cause	Remedy
Motor will not run.	No incoming power, or low voltage.	Check circuit breakers, switches and connections in power supply lines. If low voltage, have a certified electrician test incoming power.
	Rectifier damaged so that the brake won't release.	Have rectifier replaced by qualified service personnel.
	Motor damaged.	Have motor replaced by a qualified service technician.
Hoist lifts very slowly.	Overloaded.	Reduce load.
	Low voltage.	Determine cause of low voltage and bring up to within +/- 10% of the voltage listed on the hoist nameplate.
Hoist lifts but will not lower.	Broken conductor in pendant cord.	Test continuity of each conductor. Replace cable if needed.
	Up/down switch malfunctioning.	Repair or replace switch.
Hoist lowers but will not lift.	Overloaded.	Reduce load to within hoist capacity.
	Up/down switch malfunctioning.	Repair or replace switch.
	Brake malfunction.	Have brake inspected by qualified personnel. Replace if needed.
Load continues drifting down excessively when hoist is stopped.	Hoist overloaded.	Reduce load to within rated capacity.
	Grease or oil on the lining.	Have a qualified technician disassemble the brake and clean the lining.
	Brake disc is worn.	Replace brake assembly.
	Brake springs are damaged.	Replace brake springs (qualified personnel).
Motor overheats.	Excessive load or too frequent use.	Operate within rated load and according to duty cycle rating.
	Brake drags.	Adjust brake clearance (qualified personnel).
Poor engagement of chain with sprocket/sheave.	Load chain is seriously worn.	Replace load chain.
	Sprocket wheel, sheave or chain guide is seriously worn.	Replace parts as needed.
Brake chatters.	Check for greater than allowable air gap.	Replace brake assembly.
	If the brake still chatters after being replaced check the rectifier for proper operation.	Have rectifier replaced by qualified service personnel.
Limit switch failure.	Bad connection of limit switch leads.	Inspect the contacts of the leads and limit switches.
	Limit switch damaged.	Replace limit switch.

**JEH SERIES ELECTRIC HOISTS — Electrical Connections**

115V 60Hz 1~

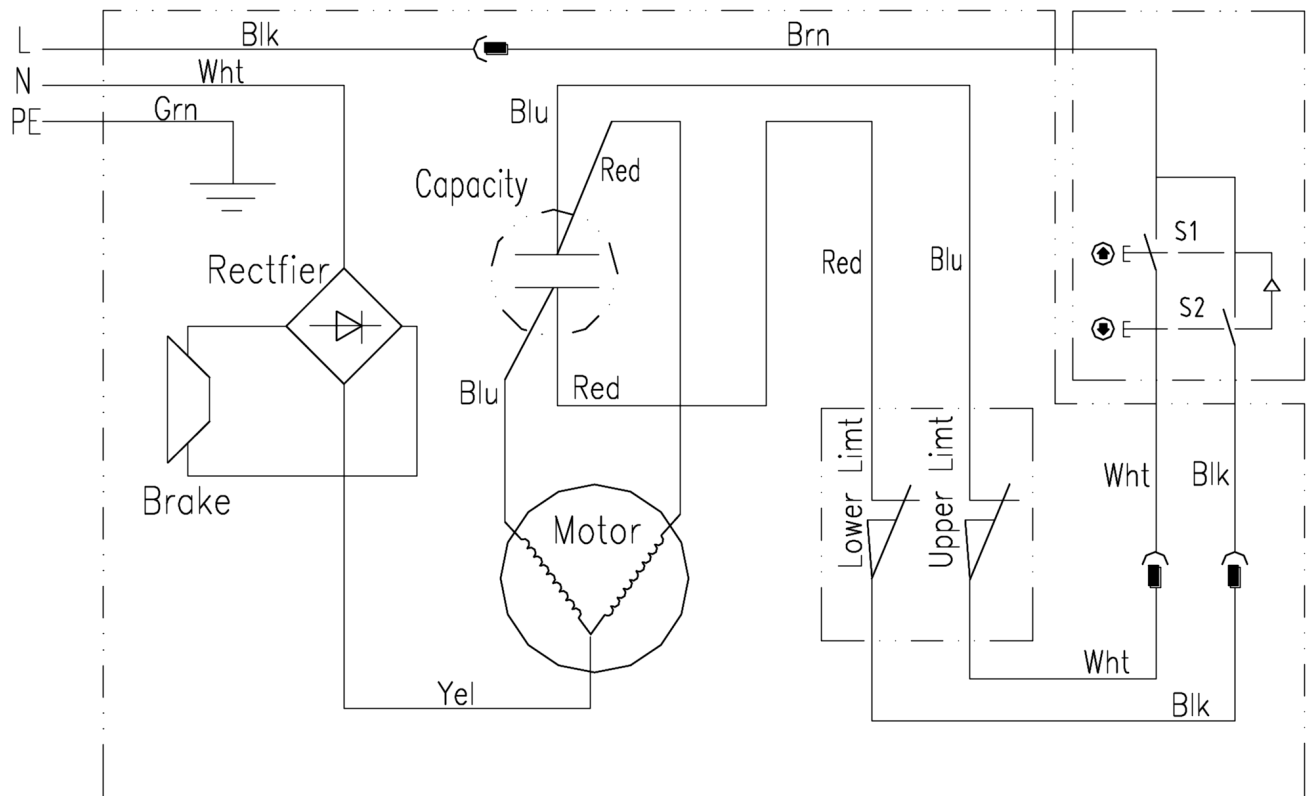

# JEH SERIES ELECTRIC HOISTS — PARTS BREAKDOWN — Prod. No. 107500, 107501

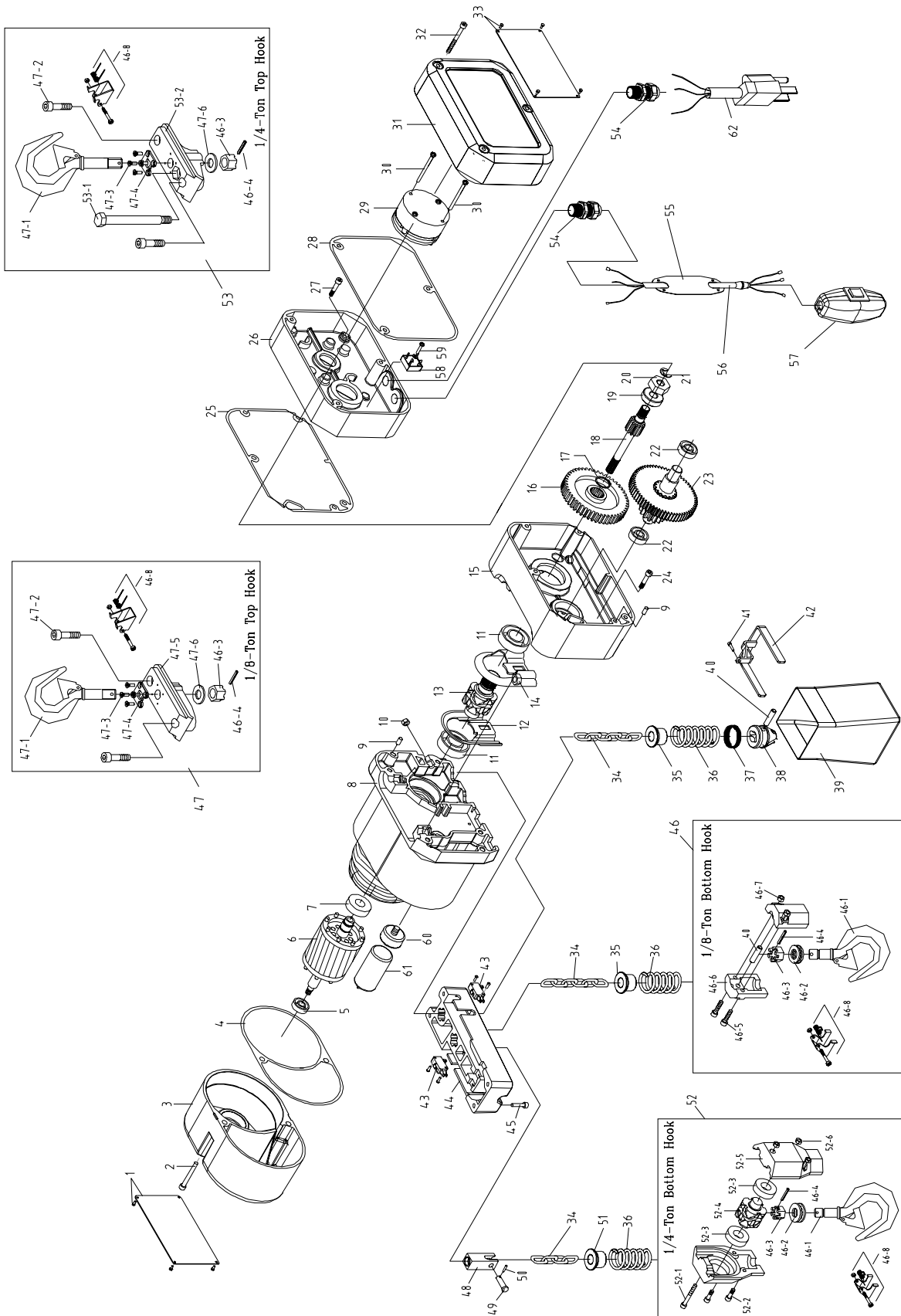

## JEH SERIES ELECTRIC HOISTS — REPLACEMENT PARTS — Prod. No. 107500, 107501

REF	PART NUMBER	DESCRIPTION	REQ	REF	PART NUMBER	DESCRIPTION	REQ
1	PZG-JEH14-01	CAPACITY LABEL FOR JEH-14	1	33	PZG-JEH14-33	ID LABEL	1
	PZG-JEH18-01	CAPACITY LABEL FOR JEH-18	1		PZG-JEH18-33	ID LABEL	1
	PZG-JEH14-1S	PHILLIPS PAN HEAD MACHINE SCREW M3X6	4		PZG-JEH14-33S	PHILLIPS PAN HEAD MACHINE SCREW M3X6	1
	PZG-JEH14-1W	PLAIN WASHER 3MM	4		PZG-JEH14-33PW	PLAIN WASHER 3MM	1
2	PZG-JEH14-2	SOCKET HEAD CAP SCREW M6x40	2	34	105321	LOAD CHAIN Ø4x12MM	
	PZG-JEH14-2W	SPRING WASHER 6MM	2	35	PZG-JEH14-35	TOUCH BLOCK A	1
	PZG-JEH14-2PW	PLAIN WASHER 6MM	2	36	PZG-JEH14-36	LIMIT SPRING	1
3	PZG-JEH14-3	MOTOR SIDE COVER	1	37	PZG-JEH14-37	RETAINER RING	1
4	PZG-JEH14-04	MOTOR CASE GASKET	1	38	PZG-JEH14-38	CHAIN STOP	1
5	PZG-JEH14-5	GROOVED BALL BEARING 6201	1	39	PZG-JEH14-39	CHAIN CONTAINER	1
6	PZG-JEH14-06	ROTOR ASSEMBLY	1	40	PZG-JEH14-40	SPRING PIN	1
7	PZG-JEH14-7	GROOVED BALL BEARING 6202	1	41	PZG-JEH14-41	SOCKET HEAD CAP SCREW M6x25	1
8	PZG-JEH14-8	MOTOR CASE ASSEMBLY	1		PZG-JEH14-41W	SPRING WASHER 6MM	1
9	PZG-JEH14-09	ROUND PIN	1		PZG-JEH14-41PW	PLAIN WASHER 6MM	1
10	PZG-JEH14-10	SELF LOCKING HEX NUT M6	1	42	PZG-JEH14-42	CHAIN CONTAINER BRACKET	1
11	PZG-JEH14-11	GROOVED BALL BEARING 6004	1	43	PZG-JEH14-43	LIMIT SWITCH	2
12	PZG-JEH14-12	CHAIN GUARD	1	44	PZG-JEH14-44	LIMIT SWITCH ASSEMBLY	1
13	PZG-JEH14-13	LIFT WHEEL	1	45	PZG-JEH14-45	SOCKET HEAD CAP SCREW M4x30	1
14	PZG-JEH14-14	SELF LOCKING HEX NUT M8	1		PZG-JEH14-45S	SPRING WASHER 4MM	1
15	PZG-JEH14-15	GEAR CASE	1		PZG-JEH14-45PW	PLAIN WASHER 4MM	1
16	PZG-JEH14-16	LIFT GEAR	1	46	PZG-JEH18-46	BOTTOM HOOK ASSEMBLY	1
17	PZG-JEH14-17	SNAP RING	1		PZG-JEH18-46-1	BOTTOM HOOK	1
18	PZG-JEH14-18	FIRST GEAR SHAFT	1		PZG-JEH18-46-2	BEARING	1
19	PZG-JEH14-19	GROOVED BALL BEARING 6000	1		PZG-JEH18-46-3	SLOTTED HEX NUT	1
20	PZG-JEH14-20	BRAKE NUT	1	46-8	PZG-JEH18-46-8	SAFETY LATCH ASSEMBLY	1
21	PZG-JEH14-21	SNAP RING 10MM	1	47	PZG-JEH18-47	TOP HOOK ASSEMBLY	1
22	PZG-JEH14-22	GROOVED BALL BEARING 6201	2		PZG-JEH18-47-1	TOP HOOK	1
23	PZG-JEH14-23	SECOND GEAR ASSEMBLY	1	48	PZG-JEH14-48	SUSPENSION CHAIN BLOCK	1
24	PZG-JEH14-24	SOCKET HEAD CAP SCREW M6x25	1	49	PZG-JEH14-49	CLEVIS PIN	1
	PZG-JEH14-24W	SPRING WASHER 6MM	1	50	PZG-JEH14-50	COTTER PIN	1
	PZG-JEH14-24PW	PLAIN WASHER 6MM	1	51	PZG-JEH14-51	TOUCH BLOCK B	1
25	PZG-JEH14-25	GEAR SIDE GASKET	1	52	PZG-JEH14-52	BOTTOM HOOK ASSEMBLY	1
26	PZG-JEH14-26	BACK FRAME	1	52-4	PZG-JEH14-52-4	SHEAVE	1
27	PZG-JEH14-27	SOCKET HEAD CAP SCREW M6x25	1	53	PZG-JEH14-53	TOP HOOK ASSEMBLY	1
	PZG-JEH14-	SPRING WASHER 6MM	1	54	PZG-JEH14-54	CABLE GLAND	1
	PZG-JEH14-	PLAIN WASHER 6MM	1	55	PZG-JEH14-55	WARNING CARD	1
28	PZG-JEH14-28	BACK FRAME GASKET	1	56	PZG-JEH14-56	PUSHBUTTON CORD 16AWGX3C PER FOOT	1ft
29	PZG-JEH14-29	BRAKE	1	57	PZG-JEH14-57	PUSHBUTTON	1
30	PZG-JEH14-30	CROSS HEAD PAN SCREW M5x65	2	58	PZG-JEH14-58	RECTIFIER 50A	1
	PZG-JEH14-30W	SPRING WASHER 5MM	2	59	PZG-JEH14-59	PHILLIPS PAN HEAD MACHINE SCREW M4x16	1
	PZG-JEH14-30PW	PLAIN WASHER 5MM	2		PZG-JEH14-59PW	PLAIN WASHER 4MM	1
31	PZG-JEH14-31	BACK FRAME COVER	1	60	PZG-JEH14-60	HOUSING FOR CAPACITOR	1
32	PZG-JEH14-32	SOCKET HEAD CAP SCREW M5x40	3	61	PZG-JEH14-61	CAPACITOR	1
	PZG-JEH14-32W	SPRING WASHER 5MM	3	62	PZG-JEH14-62	POWER CABLE ASSEMBLY	1
	PZG-JEH14-32PW	PLAIN WASHER 5MM	3		PZG-JEH14-56-10	CNTRL PENDANT ASSY 10' LIFT	1
	PZG-JEH14-32OR	O-RING Ø4x1.8	3		PZG-JEH14-56-15	CNTRL PENDANT ASSY 15' LIFT	1
					PZG-JEH14-56-20	CNTRL PENDANT ASSY 20' LIFT	1

