

# Operator's MANUAL

Prod. No. 110603  
110604

## VLP SERIES MINI LEVER PULLERS

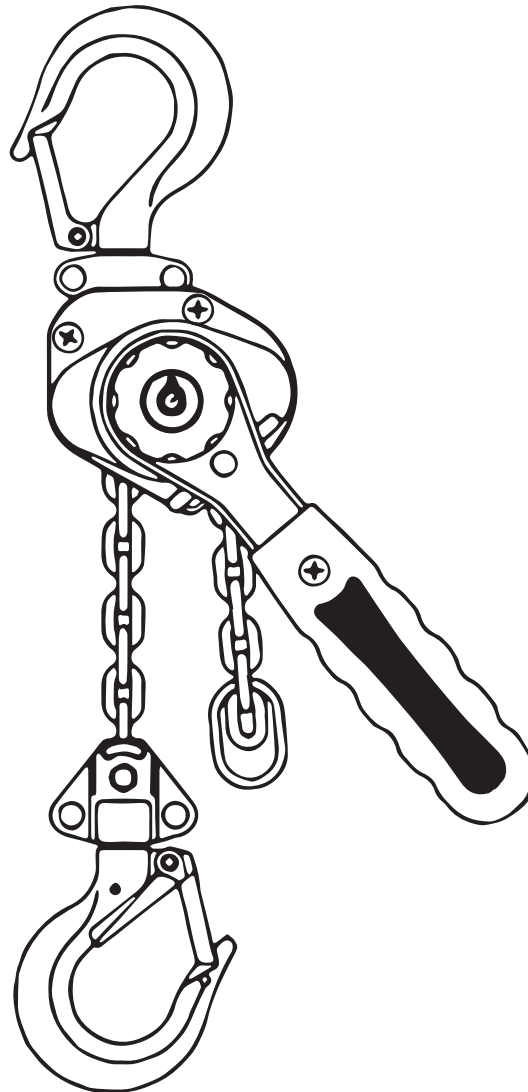

## TABLE OF CONTENTS

Warranty Policy.....	2	Precautions.....	7
Information for your safety.....	3	Inspection and maintenance.....	8
Safety precautions.....	3	Hooks.....	9
Specifications.....	4	Chain.....	10
Unpacking, installation, pre-operation inspection.....	5	Parts breakdown.....	11, 12
Operation.....	6		

## WARRANTY POLICY

JET EQUIPMENT AND TOOLS LTD. (JET®) makes every effort to ensure its products are manufactured to the highest standards and are guaranteed against defects in materials and workmanship when the product is used for the purpose for which it was designed.

This guarantee applies only to JET products purchased new from a JET authorized distributor.

JET product warranties are extended to the original retail purchaser only. This warranty does not apply to any product showing signs of abuse, misuse, alteration, or having been improperly maintained or repaired.

This warranty does not cover damage attributable to normal wear and tear.

Any JET product that fails during normal use and is within the specified warranty period for that product will be repaired or replaced at JET's discretion. Repairs and/or replacements are warranted as described for the specific product and only for the remainder of the original warranty period.

Repair or replacement is the exclusive remedy for defective product under this warranty.

Warranty is expressly in lieu of all other warranties, including the implied warranty of merchantability or any implied warranty of fitness for a particular application.

Any JET product for which there is a warranty claim should be returned PREPAID to an authorized JET distributor or service centre. Authorized Warranty Depots are found at [surewerx.com](http://surewerx.com)

ALL warranty claims must be accompanied by proof of purchase and an explanation of the defect or failure. It is the customer's responsibility to provide this information.

JET shall not be held liable for any consequential or incidental damages for breach of any expressed or implied warranty on their products. No claims for damages of any type will be considered and all products are sold with this understanding.

Any costs incurred to obtain warranty consideration or services are the Customer's responsibility including shipping and handling, travel, lost time, or lost production.

## SPECIFIED WARRANTY – MATERIAL HANDLING

### 1 Year Limited Warranty

- Chain Hoists Hand Cable Pullers
- Air Hoists Lever Chain Pullers
- Electric Hoists Grip Pullers
- Electric Trolleys Manual Adjustable Trolleys
- Drum Clamps Beam Clamps
- Plate Clamps Blocks and Sheaves
- Pallet Trucks Mobile Lift Tables
- Winches

## GENERAL INFORMATION ON JET CHAIN HOISTS AND PULLERS

**Customs Lifts** – Custom lift lengths are available, however, custom lift hoists and pullers are NOT returnable.

**CAUTION:** be sure that supporting structures and load-attaching devices used in conjunction with hoists, provide an adequate safety factor to handle the rated load plus the weight of the equipment. If in doubt, consult a qualified structural engineer.

This equipment is not to be used for lifting, supporting, or transporting people, or lifting, supporting, or transporting loads over people.

**IMPORTANT:** Before installation and operation, see maintenance and operations manual for additional warnings, precautions and operating instructions.

**NOTE:** Batteries supplied with certain products may have been subjected to long shelf life, resulting in low energy or a dead battery. Please source replacement batteries locally. Please follow instructions in the manuals for products using rechargeable batteries. Dead batteries do not constitute a warranty claim.

## INFORMATION FOR YOUR SAFETY

It is the responsibility of the owner/user to install, inspect, test, maintain, and operate these lever hoists in accordance with ASME B30.21, Safety Standard for Manually Operated Lever Hoists.

These general instructions deal with the normal installation, operation and maintenance situations encountered with the lever hoists described herein. The instructions should not be interpreted to anticipate every possible contingency or to anticipate the final system or configuration that uses these lever hoists.

These instructions include information for a variety of lever hoists. Therefore, all instructions and information may not apply to one specific lever hoist. Disregard those portions of the instructions that do not apply.

If the lever hoist owner/user requires additional information, or if any information in these instructions are not clear, contact your local JET Material Handling Products distributor.

This lever hoist should not be installed, operated, or maintained by any person who has not read all the contents of these instructions, and ASME B30.21, Safety Standard for Manually Operated Lever Hoists. Failure to read and comply with these instructions or any of the warnings or limitations noted herein can result in serious bodily injury or death, and/or property damage.

Only trained and qualified personnel shall operate and maintain this equipment.

Equipment described herein is not designed for, and should not be used for lifting, supporting, or transporting people.

User should not use this lever hoist in conjunction with other equipment unless necessary and/or required safety devices applicable to the system are installed by the user.

Modifications to upgrade, rerate or otherwise alter these lever hoists shall be authorized only by the original equipment manufacturer or qualified professional engineer.

## SAFETY PRECAUTIONS

**A. READ these instructions and ASME B30.21, Safety Standard for Manually Operated Lever Hoists before installing, operating, or maintaining this equipment.**

**B. WARN personnel of approaching loads.**

**C. DO NOT**

1. Lift more than rated load.
2. Operate lever hoist when it is restricted from forming a straight line with the direction of loading.
3. Operate with twisted, kinked, or damaged chain.
4. Operate if chain is not seated in sheaves or sprockets.
5. Wrap chain around load or use chain as a sling.
6. Operate unless load is properly applied to the saddle or bowl of the hook.
7. Operate if load is applied to the tip of the hook.
8. Operate with damaged or missing hook latches.
9. Lift people or lift loads over people.
10. Operate with side-pulling or side-loading of load to lever hoist.
11. Operate a damaged or malfunctioning lever hoist.
12. Operate with other than hand power.
13. Remove, deface, or obscure warning label or labels on lever hoist.
14. Leave load suspended when lever hoist is unattended unless specific precautions have been instituted and are in place.
15. Lengthen load chain or repair damaged load chain by welding.
16. Use chain as a ground for welding.
17. Hammer on lever.
18. Use extensions on lever.
19. Lift one load with more than one lever hoist, unless each lever hoist is rated to support the entire load in the event one or more lever hoists is disabled, shifting load to the other lever hoists.

## SPECIFICATIONS (VLP-25/VLP-50)

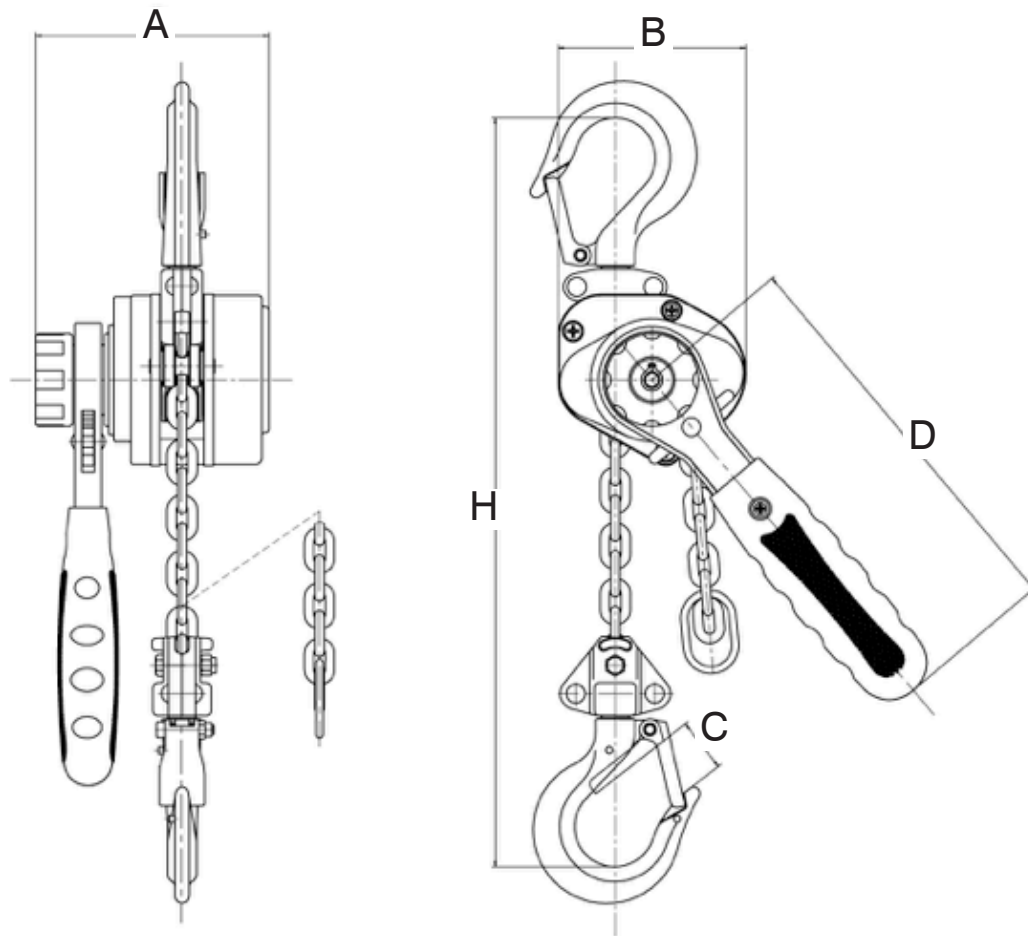

Prod. No.	110603	110604
Mod. No.	VLP-25	VLP-50
Rated Capacity (Ton)	0.25	0.50
Standard Lift (Foot)	5	5
Minimum Distance Between Hooks (Inch) - "H"	8.3	10
Number of Falls	1	1
Load Chain Diameter (mm)	4	4.3
Lbs. Pull to Lift Capacity	61	81
Lever Length (Inch) - "D"	5.9	8.5
Overall Depth (Inch) - "B"	2-7/16	2-5/8
Overall Width (Inch) - "A"	3-1/8	3-3/4
Hook Throat Opening (Inch) - "C"	1-3/8	1-5/8
Net Weight (lb)	4.4	5.2

## UNPACKING

Open carton and check for shipping damage. Report any damage immediately to your distributor and shipping agent. Do not discard any shipping material until the Lever Hoist is assembled and running properly. Read this entire instruction manual thoroughly for set-up, maintenance and safety instructions.

### Contents of the Carton

- 1 Lever Hoist
- 1 Carry Pouch
- 1 Owner's Manual
- 1 Load Test Certificate

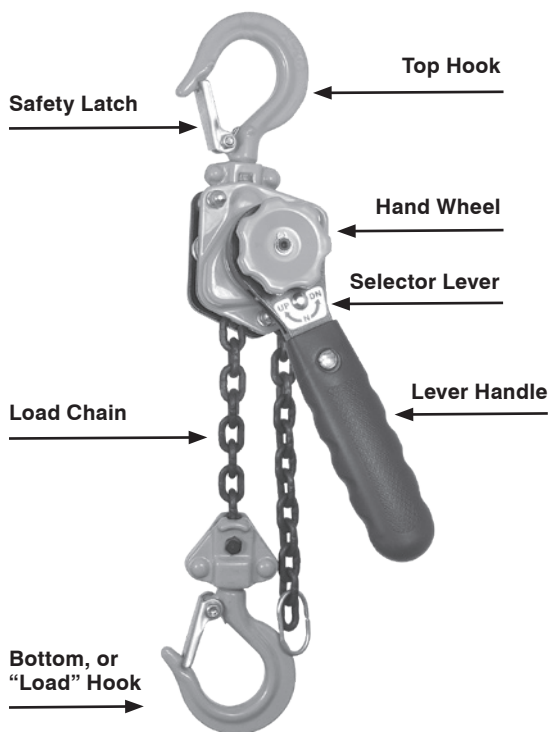

Figure 1  
Features and terminology

## INSTALLATION

Support for the hoist may be hook, clevis pin, trolley, or beam clamp. Whatever method of suspension is chosen, the support components must be rated equal to, or greater than the capacity of the lever hoist. Supporting structures (such as I-Beams, etc.) should be installed by properly licensed professional installers.

## PRE-OPERATION INSPECTION

### Inspecting the Load Chain

1. A chain stop must be attached to the second-to-last link on the slack end of the chain. See Figure 2.

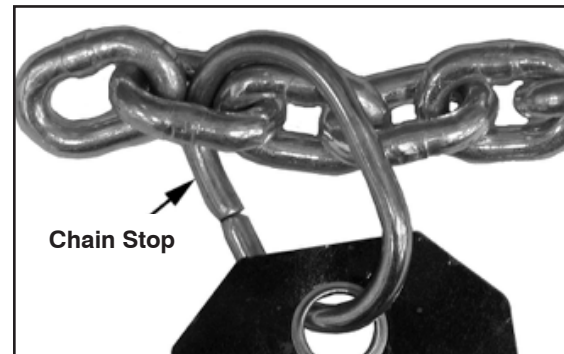

Figure 2

**Do not operate the hoist with a twisted, kinked or damaged chain. Do not splice the chain.**

2. Check that the chain does not twist along its length from hoist to hook. If twist is present on units with multiple falls, the hook must be passed back through the chain loop to remove all twist in the chain.
3. Replace the chain if links are stretched or seriously worn on the surface, especially at the points where links contact each other. Do not use a chain that is seriously rusted or cracked.
4. Periodically apply a light coat of 30W oil to the chain. This will create easier operation and prolong the chain's life. For optimum results, clean the chain with an acid-free solution before oiling.

**The load chain supplied with your lever hoist is designed, manufactured, and tested for proper fit and durability. If chain should ever need replacing, for your own safety use factory replacement chain only. Use of other than factory replacement chain may cause serious injury and/or damage to the lever hoist.**

Never extend load chain by welding a second piece to the original.

## OPERATION

### Before initial operation of hoist:

1. Read and comply with all instructions and warnings furnished with or attached to lever hoist.
2. Check lubricant.
3. Check operation of brake.
4. Check that chain is properly seated in sheaves and that chain is not twisted, kinked, or damaged.

### Before each shift:

1. Inspect hooks for nicks, gouges, cracks, and signs of pulling apart or twisting.
2. Inspect hook latch for proper operation.
3. Check chain for kinks or twists.
4. Check operation of brake.
5. Replace warning label if missing or illegible.

### Before operating:

1. Be certain all personnel are clear of the load to be lifted and moved.
2. Make sure load will clear stock piles, machinery, or other obstructions when hoisting and travelling the load.
3. Eliminate any twists or kinks in the load chain.

JET Lever Hoists may be used either in vertical position as a hoist; or in angled or horizontal position as a puller. Below is the general procedure for operating the hoist:

1. Set the top hook securely.
2. Correctly center the load on the bottom hook (Figure 3). Incorrect loading is dangerous to the operator, the lever hoist, and the load.
  - Never load the hook in front of the safety latch (A, Figure 4).
  - Never load the hook tip (B, Figure 4).
  - Never load the hook off the centerline (C, Figure 4).
  - Never load the hook sideways (D, Figure 4)

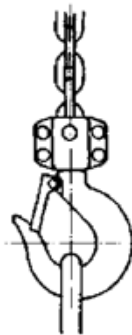

**Correct**

Figure 3

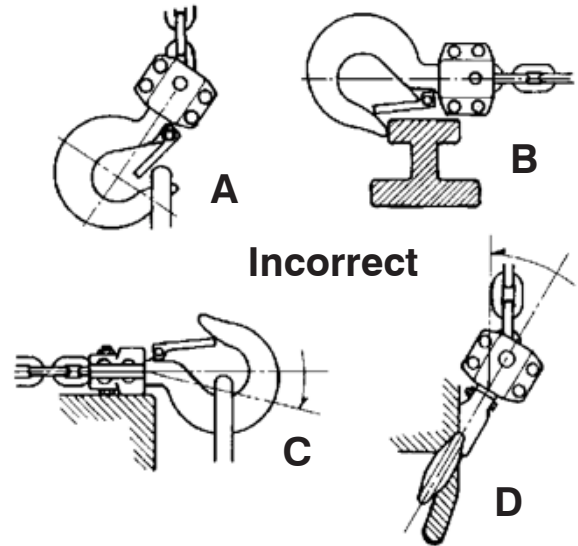

Figure 4

3. Rotate the handwheel clockwise while simultaneously pulling down on the load chain. The handwheel will snap back into place, re-engaging the gear.
4. Move selector switch to the UP position. Ratchet the lever to raise or pull the load. Do not overload the lever hoist.

**Do not touch the handwheel while lifting or lowering. Do not operate freewheel mode while there is a load on the hoist.**

5. To release or lower the load, turn selector switch on the handle to the DOWN position and ratchet the handle.

**NOTE:** If the chain is pulled too suddenly in free-wheel mode, the brake may set preventing further pulling. Re-set the hoist by repeating step number 3 above, and then set the hoist back into freewheel mode to continue the operation.

Avoid lifting one load with two hoists. If this is unavoidable, apply equal weight to both hoists and use hoists with the proper lift capacity. **Capacity of each hoist must be equal to the total load to be lifted.**

## PRECAUTIONS

- During lifting operations, do not stand under the load.
- Do not use any extension on the lever handle. Do not use your foot to apply pressure to the lever handle.
- Prevent the chain from dragging over sharp edges or corners. This will cause links to weaken, bend, or break.
- When connecting to a wire rope sling, the lever hoist must be applied along a straight line parallel to the surface on which it is resting. See Figure 5.
- When lifting loads, hook the load with slings. **Do not use the lever hoist chain as a sling (Figure 6).**
- Both ends of a sling or rope must be completely on the inside of the safety latch before pulling or lifting the load. Do not put one end on the inside of the latch and leave the other end on the hook end outside the latch.

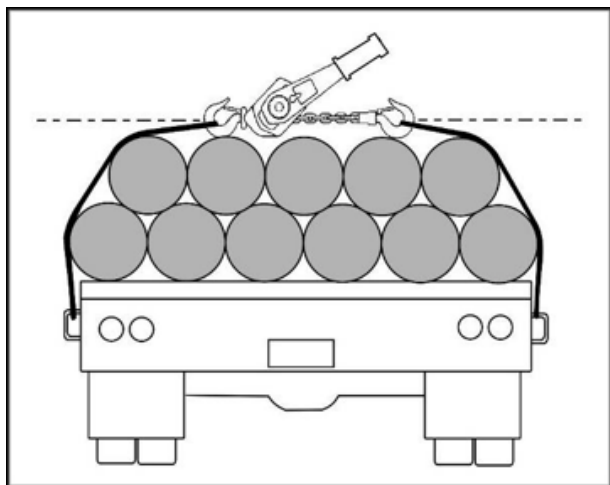

Figure 5

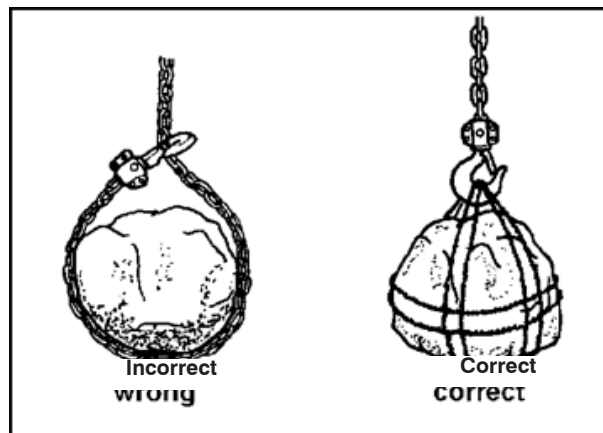

Figure 6

## INSPECTION AND MAINTENANCE

Prior to initial use, all new, modified, and repaired hoists should be inspected in accordance with Table 2. Thereafter, inspections should be conducted at intervals shown in Table 1; and items to be inspected are indicated in Table 2 by **F** (Frequent) or **P** (Periodic).

**Frequent inspections** – Visual inspection by the operator or other authorized person. This inspection includes listening for unusual sounds while the hoist is operated that may indicate deficiencies.

**Periodic Inspections** – Audible-visual inspection as for Frequent Inspections, with some disassembly to allow a more detailed inspection if external conditions indicate needed.

**Exceptions** – Brakes require more than audible-visual inspection. Check daily by operating the lever hoist with and without load, stopping at various positions to test holding power and amount of drift, if any occurs.

**TABLE 1 - FREQUENCY OF INSPECTION**

SERVICE	FREQUENT (F) INSPECTION	PERIODIC (P) INSPECTION
Normal	Monthly	Annually
Heavy	Weekly to Monthly	Semi-Annually
Severe	Daily to Weekly	Quarterly

**TABLE 2 - INSPECTION CHART**

In chart, **F** indicates Frequent Inspection, **P** indicates Periodic Inspection

LOCATION	CHECK FOR	F	P	LOCATION	CHECK FOR	F	P
Braking mechanism	Slipping under load	✗		Hook Retaining Members (Pins, Bolts, Nuts)	Not tight or secure		✗
	Hard to release	✗			Hook Latch	Damaged; does not close	✗
Brake Parts	Glazing		✗	Suspension Members (Sheaves, hand-wheels, chain attachments, suspension bolts or pins)		Excessive wear	
Brake Discs		Oil contamination			✗	Cracks	✗
Pawl; Ratchet	Excessive wear		✗	Gears	Distortion		✗
Pawl Spring	Corrosion; stretch		✗		Broken or worn teeth		✗
Hooks	Chemical damage	✗			Cracks		✗
	Deformation	✗		Inadequate lubrication		✗	
	5% in excess of normal throat opening		✗	Load Block; Suspension Housing	Distortion	✗	✗
	10° twist from plane of unbent hook		✗		Cracks	✗	✗
	Cracks (dye penetrant, magnetic particle, or other suitable detection method)			✗	Trolley; Supporting Structure	Possible inability to continue supporting imposed loads	
				Bolts, Nuts, Rivets	Not tight or secure		✗
				WARNING Label	Removed or illegible	✗	

## HOOKS

### WARNING

1. Any hook that requires replacement because of excessive bends, twists, or throat opening indicates abuse or overloading of the hoist. Therefore, other load-supporting components of the lever hoist should be inspected for possible damage when such conditions are found.
2. Never repair hooks by welding or reshaping. Heat applied to the hook will alter the original heat treatment of the hook material and reduce the strength of the hook.
3. Never weld handles or other attachments to the hook. Heat applied to the hook will alter the original heat treatment of the hook material and reduce the strength of the hook.

### HOOKS INSPECTION

Refers to ASME B30.10, Safety Standard for Hooks. Inspect hooks and measure hook throat opening at least once a month. Between regular inspections check visually daily for deformation, distortion, twisting, damage, and missing or damaged hook latches. Inspect as follows:

1. Measure hook opening at raised dots (Figure 7) to check for stretch. Raised dots provide a constant reference point and eliminate measurement errors. Replace hook when measurement between dots reaches "Dimension A Replace Hook" figures below.

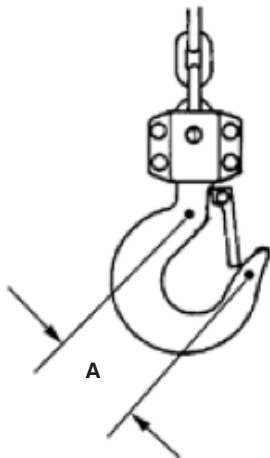

Figure 7

Hoist Capacity	"A" Dimension Normal (mm)	"A" Dimension Replace Hook if $\geq$ (mm)
0.25 ton	35.5	37.3
0.50 ton	41	43.1

2. A bend or twist of the hook exceeding  $10^\circ$  from the plane of the unbent hook requires replacement of the hook.
3. A hook latch that is missing shall be replaced.
4. A hook latch that is inoperative shall be repaired or replaced.
5. A hook with a hook latch that does not close the throat opening of the hook shall be removed from service until the latch is replaced or repaired.
6. Hooks having damage from chemicals, corrosion, or deformation shall be repaired or replaced.

**Due to variations in the manufacturing process, the dimensions of a new hook are variable. For accurate record keeping, we recommend users record measurement of Dimension A of the hook before use. Record this information in the spaces above and calculate the replacement value by multiplying by 1.05 for Dimension A.**

## CHAIN

Inspect chain at least once a month. Between regular inspections, check visually daily for nicks, gouges, weld splatter, corrosion, or distorted links. Inspect chain thoroughly if it does not feed smoothly over load sheaves. Inspect as follows:

1. Clean chain with solvent before inspection.
2. Test hoist with load and observe operation of chain over load sheaves.

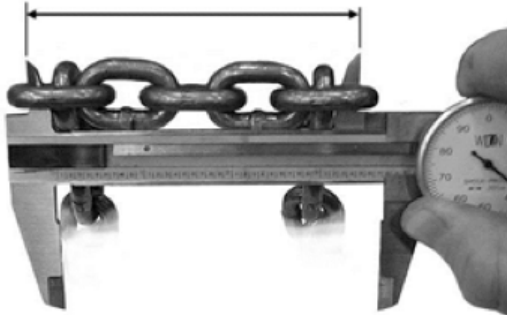
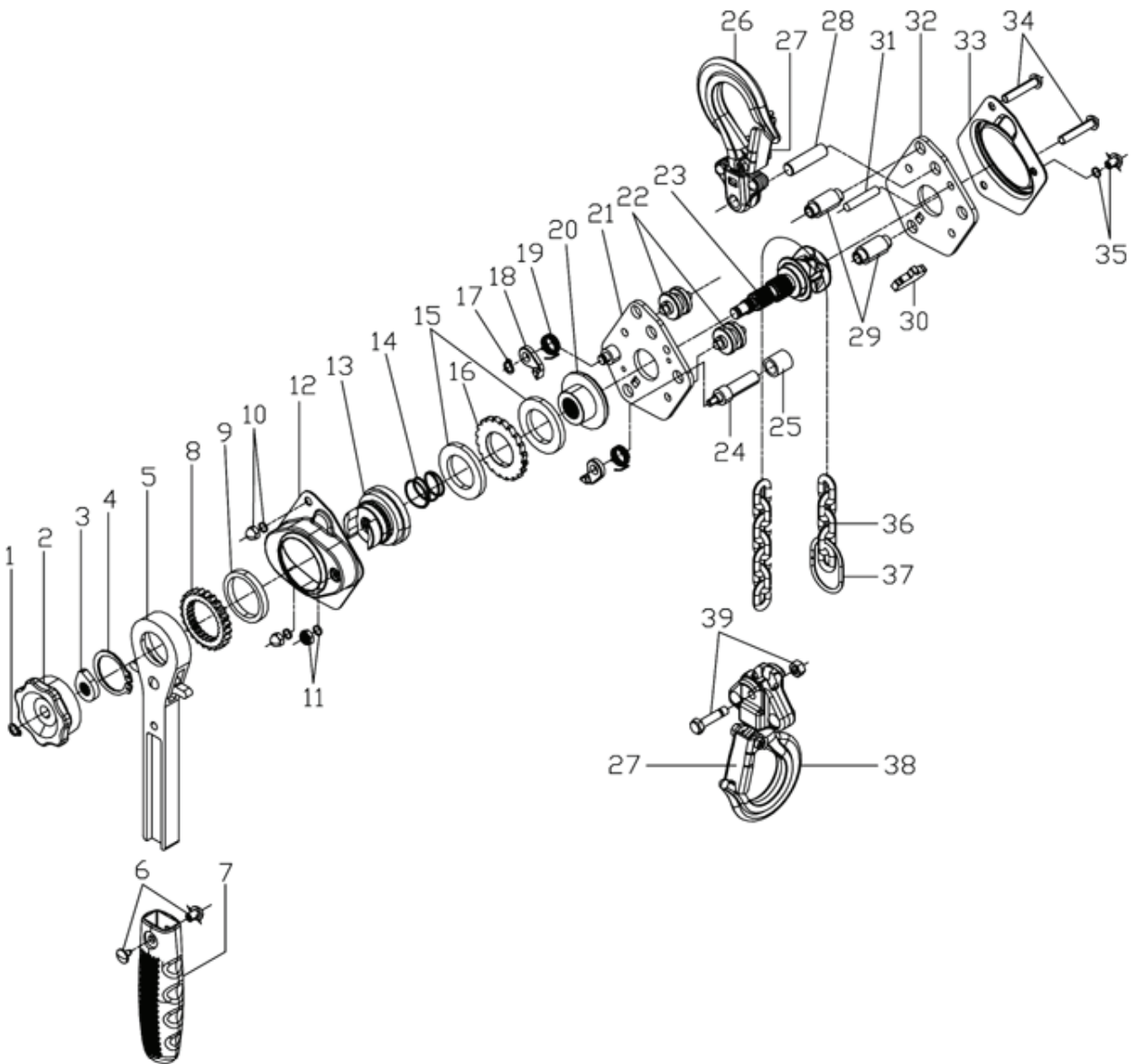

Figure 8

Hoist Capacity	5 Links Normal (mm)	5 Links Limit Replace if $\geq$ (mm)
0.25 ton	58	59.75
0.50 ton	58	59.75

3. Slacken chain and inspect contact points for excessive wear. Refer to Figure 2.
4. Using caliper-type gauge, measure inside length of 5 links under light tension. Refer to Figure 8. Replace chain if measurement exceeds maximum allowable gauge length as above.
5. Chain oiling is not mandatory but will increase the life of the chain.

**VLP-25-5 1/4 T, VLP-50-5 1/2 T LEVEL HOIST PROD. NO. 110603, 110604**



## VLP-25-5 1/4 T, VLP-50-5 1/2 T LEVEL HOIST PROD. NO. 110603, 110604

REF	PART NUMBER	DESCRIPTION	REQ	REF	PART NUMBER	DESCRIPTION	REQ
1	PVI-VLP25-01	SNAP RING 0.7 mm	1	20	PVI-VLP50-20	BRAKE SEAT	1
1	PVI-VLP50-01	SNAP RING	1	21	PVI-VLP25-21	LEVER SIDE PLATE ASSEMBLY	1
2	PVI-VLP25-02	HAND WHEEL	1	21	PVI-VLP50-21	LEVER SIDE PLATE ASSEMBLY	1
2	PVI-VLP50-02	HAND WHEEL	1	22	PVI-VLP25-22	CHAIN GUIDE	2
3	PVI-VLP25-03	CAM GUIDE	1	22	PVI-VLP50-22	CHAIN GUIDE	2
3	PVI-VLP50-03	CAM GUIDE	1	23	PVI-VLP25-23	LOAD SPROCKET AND PINION SHAFT	1
4	PVI-VLP25-04	SNAP RING 0.25 mm	1	23	PVI-VLP50-23	LOAD SPROCKET AND PINION SHAFT	1
4	PVI-VLP50-04	SNAP RING	1	24	PVI-VLP25-24	STAY BLOT II	1
5	PVI-VLP25-05	LEVER HANDLE ASS W 6,7	1	24	PVI-VLP50-24	STAY BLOT II	1
5	PVI-VLP50-05	LEVER HANDLE ASS W 6,7	1	25	PVI-VLP25-25	SPACER PIN	1
6	PVI-VLP25-06	BOLT&NUT	1	25	PVI-VLP50-25	SPACER PIN	1
6	PVI-VLP50-06	BOLT&NUT	1	26	PVI-VLP25-26	TOP HOOK ASSEMBLY	1
7	PVI-VLP25-07	ROBBER GRIP	1	26	PVI-VLP50-26	TOP HOOK ASSEMBLY	1
7	PVI-VLP50-07	ROBBER GRIP	1	27	PVI-VLP25-27	SAFETY LATCH KIT	2
8	PVI-VLP25-08	CHANGE OVER GEAR	1	27	PVI-VLP50-27	SAFETY LATCH KIT	2
8	PVI-VLP50-08	CHANGE OVER GEAR	1	28	PVI-VLP25-28	TOP HOOK SHAFT	1
9	PVI-VLP25-09	BUSHING	1	28	PVI-VLP50-28	TOP HOOK SHAFT	1
9	PVI-VLP50-09	BUSHING	1	29	PVI-VLP25-29	STAY BOLT	1
10	PVI-VLP25-10	COVER NUT & SPRING WASHER	2	29	PVI-VLP50-29	STAY BOLT	1
10	PVI-VLP50-10	COVER NUT & SPRING WASHER	2	30	PVI-VLP25-30	CHAIN STRIPPER	1
11	PVI-VLP25-11	HEX SCREW NUT & SPRING WASER	1	30	PVI-VLP50-30	CHAIN STRIPPER	1
11	PVI-VLP50-11	HEX SCREW NUT & SPRING WASER	1	31	PVI-VLP25-31	HOOK HOLDER PROTECTION PIN	1
12	PVI-VLP25-12	BRAKE COVER	1	31	PVI-VLP50-31	HOOK HOLDER PROTECTION PIN	1
12	PVI-VLP50-12	BRAKE COVER	1	32	PVI-VLP25-32	RIGHT SIDE PLATE	1
13	PVI-VLP25-13	BRAKE PLATE	1	32	PVI-VLP50-32	RIGHT SIDE PLATE	1
13	PVI-VLP50-13	BRAKE PLATE	1	33	PVI-VLP25-33	GEAR SIDE PLATE COVER	1
14	PVI-VLP25-14	TWISTING SPRING	1	33	PVI-VLP50-33	GEAR SIDE PLATE COVER	1
14	PVI-VLP50-14	TWISTING SPRING	1	34	PVI-VLP25-34	SOCKET HEAD SCREW	2
15	PVI-VLP25-15	FRICTION DISC	2	34	PVI-VLP50-34	SOCKET HEAD SCREW	2
15	PVI-VLP50-15	FRICTION DISC	2	35	PVI-VLP25-35	SOCKET HEAD SCREW & S WASHER	1
16	PVI-VLP25-16	RATCHET DISC	1	35	PVI-VLP50-35	SOCKET HEAD SCREW & S WASHER	1
16	PVI-VLP50-16	RATCHET DISC	1	37	PVI-VLP25-37	END RING	1
17	PVI-VLP25-17	SNAP RING	1	37	PVI-VLP50-37	END RING	1
17	PVI-VLP50-17	SNAP RING	1	38	PVI-VLP25-38	BOTTOM HOOK ASSEMBLY	1
18	PVI-VLP25-18	PAWL	2	38	PVI-VLP50-38	BOTTOM HOOK ASSEMBLY	1
18	PVI-VLP50-18	PAWL	2	39	PVI-VLP25-39	LOCKING NUT & CHAIN PIN	1
19	PVI-VLP25-19	PAWL SPRING	2	39	PVI-VLP50-39	LOCKING NUT & CHAIN PIN	1
19	PVI-VLP50-19	PAWL SPRING	2	NS	PVI-VLP25-NP	NAME PLATE	1
20	PVI-VLP25-20	BRAKE SEAT	1	NS	PVI-VLP50-NP	NAME PLATE	1