

Operation MANUAL

JEH Series Chain Hoists

Prod. No. 107502
Mod. No. JEH-12S

Prod. No. 107503
Mod. No. JEH-1S

Prod. No. 107504
Mod. No. JEH-2S

Prod. No. 107505
Mod. No. JEH-3S

Prod. No. 107506
Mod. No. JEH-5S

Prod. No. 107513
Mod. No. JEH-1

Prod. No. 107514
Mod. No. JEH-2

Prod. No. 107515
Mod. No. JEH-3

Prod. No. 107516
Mod. No. JEH-5



TABLE OF CONTENTS

Introduction.....	4	Installing Chain Container	9	Inspection Procedures:	
Description.....	4	Pre-Operation Inspection	10	Allowable Limits	17
Specifications — Single Phase.....	5	Inspecting the Load Chain	10	Load Chain	17
Specifications — Three Phase.....	6	Inspecting the Hooks.....	11	Hooks (Top and Bottom)	17
Unpacking.....	7	Operating the Hoist.....	11	Brake Friction Pad	18
Contents of the		Adjustments	12	Chain Container Chart for	
Shipping Container.....	7	Safety Clutch Adjustment	12	Standard or Custom Lifts	18
Installation	7	Replacing Load Chain.....	12	Troubleshooting	19
Installing Top Hook.....	7	How to Cut Chains.....	12	Replacement Parts	
Installing Power and		Making a C-Link	12	1/2-Ton Chain Hoist.....	20
Pendant Cords.....	7	Single Fall Chain Hoist.....	13	1-Ton and 2-Ton Chain Hoists	23
Electrical Instructions.....	8	Vertical and Horizontal Links.....	13	3-Ton Chain Hoist	27
Grounding.....	8	Dual/Multiple Fall Chain Hoists ...	14	5-Ton Chain Hoist	31
Voltage Conversion	8	Brake Adjustment	15	Electrical Connections	
Inspecting Hoist Motion	8	Inspection Schedule A.....	16	1-Phase.....	35
Extension Cords.....	9	Inspection Schedule B.....	16	3-Phase	36

WARRANTY POLICY

JET EQUIPMENT AND TOOLS LTD. (JET®) makes every effort to ensure its products are manufactured to the highest standards and are guaranteed against defects in materials and workmanship when the product is used for the purpose for which it was designed.

This guarantee applies only to JET products purchased new from a JET authorized distributor.

JET product warranties are extended to the original retail purchaser only. This warranty does not apply to any product showing signs of abuse, misuse, alteration, or having been improperly maintained or repaired.

This warranty does not cover damage attributable to normal wear and tear.

Any JET product that fails during normal use and is within the specified warranty period for that product will be repaired or replaced at JET's discretion. Repairs and/or replacements are warranted as described for the specific product and only for the remainder of the original warranty period.

Repair or replacement is the exclusive remedy for defective product under this warranty.

Warranty is expressly in lieu of all other warranties, including the implied warranty of merchantability or any implied warranty of fitness for a particular application.

Any JET product for which there is a warranty claim should be returned PREPAID to an authorized JET distributor or service centre. Authorized Warranty Depots are found at surewerx.com

ALL warranty claims must be accompanied by proof of purchase and an explanation of the defect or failure. It is the customer's responsibility to provide this information.

JET shall not be held liable for any consequential or incidental damages for breach of any expressed or implied warranty on their products. No claims for damages of any type will be considered and all products are sold with this understanding.

Any costs incurred to obtain warranty consideration or services are the Customer's responsibility including shipping and handling, travel, lost time, or lost production.

SPECIFIED WARRANTY — MATERIAL HANDLING

1 Year Limited Warranty

Chain Hoists Hand Cable Pullers
 Air Hoists Lever Chain Pullers
 Electric Hoists Grip Pullers
 Electric Trolleys
 Manual Adjustable Trolleys
 Drum Clamps Beam Clamps
 Plate Clamps Blocks and Sheaves
 Pallet Trucks Mobile Lift Tables
 Winches

GENERAL INFORMATION ON JET CHAIN HOISTS AND PULLERS

Customs Lifts — Custom lift lengths are available, however, custom lift hoists and pullers are NOT returnable.

CAUTION: Be sure that supporting structures and load-attaching devices used in conjunction with hoists, provide an adequate safety factor to handle the rated load plus the weight of the equipment. If in doubt, consult a qualified structural engineer.

This equipment is not to be used for lifting, supporting, or transporting people, or lifting, supporting, or transporting loads over people.

IMPORTANT: Before installation and operation, see maintenance and operations manual for additional warnings, precautions and operating instructions.

NOTE: Batteries supplied with certain products may have been subjected to long shelf life, resulting in low energy or a dead battery. Please source replacement batteries locally. Please follow instructions in the manuals for products using rechargeable batteries. Dead batteries do not constitute a warranty claim.

WARNINGS

1. Read and understand the entire owner's manual before attempting assembly or operation.
2. Read and understand the warnings posted on the machine and in this manual. Failure to comply with all of these warnings may cause serious injury.
3. Replace the warning labels if they become obscured or removed.
4. This chain hoist is designed and intended for use by properly trained and experienced personnel only. If you are not familiar with the proper and safe operation of a chain hoist, do not use until proper training and knowledge have been obtained.
5. Do not use this chain hoist for other than its intended use. If used for other purposes, JET Equipment & Tool (JET®) disclaims any real or implied warranty and holds itself harmless from any injury that may result from that use.
6. Do not install this chain hoist where explosive hazards may exist.
7. Give your work your undivided attention. Looking around, carrying on a conversation and "horse-play" are careless acts that can result in serious injury.
8. Do not use to lift people or loads over people. Warn others in the vicinity when lifting or transporting a load. Avoid swinging load and hook.
9. Do not exceed the rated capacity of the chain hoist.
10. Make sure limit switches are operating properly. Do not use limit switches as routine operating stops; they are emergency devices only.
11. Do not use the load chain as a sling; this may cause damage to the chain.
12. Maintain firm footing when operating the hoist.
13. Always inspect the chain hoist for damage prior to use. Do not use a chain hoist with twisted, kinked, worn or otherwise damaged chain. If the chain hoist is damaged, do not use until it has been repaired or replaced.
14. Do not use more than one chain hoist to lift or move a load. If this is unavoidable, each chain hoist must have the same capacity as the load to be moved.
15. Never allow the load chain to "set" over sharp edges. All lifts must be made with straight chain that is free of obstacles.
16. Do not use a chain hoist unless load is centred between top and bottom hooks.
17. Protect load chain from weld splatter and other contaminants. Do not allow the hook or chain to be contacted by a live welding electrode.
18. Always take time to study the job to be performed and choose the safest method. Do not place yourself or other people in an unsafe position.
19. Leave all internal maintenance to a qualified JET Equipment & Tools LTD (JET®) service centre.
20. Replace the chain with factory replacement chain only. Do not use any other type of chain.
21. Never use the chain hoist if either hook is stretched, deformed, or has a broken or missing safety latch. Always replace the safety latch and/or the hook before placing the chain hoist back into service.
22. Do not operate this hoist while tired or under the influence of drugs, alcohol or any medication.
23. Understand and follow all procedures as set forth in American National Standards titled "Performance Standard for Hand Chain Manually Operated Chain Hoists." ANSI/ASME HST-2M. This standard is available through the American Society of Mechanical Engineers, 345 East 47th St., NY, NY 10017.
24. Do not use in wet, damp, or poorly lit locations. This hoist is not rated for outside use.

Familiarize yourself with the following safety notices used in this manual:

⚠ CAUTION This means that if precautions are not heeded, it may result in minor injury and/or possible machine damage.

⚠ WARNING This means that if precautions are not heeded, it may result in serious or even fatal injury.

INTRODUCTION

This manual is provided by JET Equipment & Tools LTD (JET®), covering the safe operation and maintenance procedures for a JET Electric Chain Hoist. This manual contains instructions on installation, safety precautions, general operating procedures, maintenance instructions and parts breakdown. This machine has been designed and constructed to provide years of trouble-free operation if used in accordance with instructions set forth in this manual. If there are any questions or comments, please contact either your local supplier or (JET®).

DESCRIPTION

JET, JEH electric chain hoist models comply with CUL and ANSI B30.16 standards and are available in single-speed, 115V/230V single phase or 230V/460V three-phase electrical configurations.

All JET® Electric Chain Hoists are available in custom configurations and can be modified to meet your required lift lengths. Contact your local dealer or JET® for more information.

⚠ WARNING Read and understand the entire contents of this manual before attempting set-up or operation! Failure to comply may cause serious injury.

Record your purchase information here for quick reference:

Model No.:
Stock No.:
Serial No.:
Purchased From:
Date Purchased:
Date Installed:
Installer:

SPECIFICATIONS — SINGLE PHASE

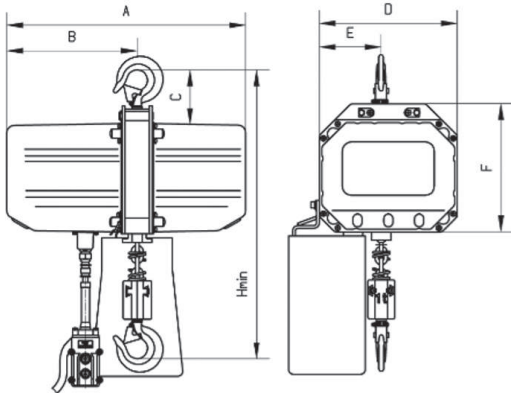

HHXG31DS — 1/2BHX, HHXG41DS — 1BHX

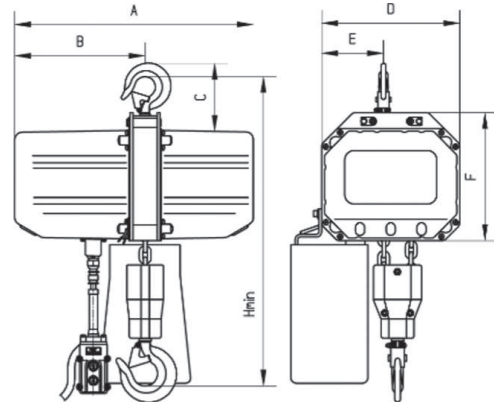

HHXG42AS — 2BHX

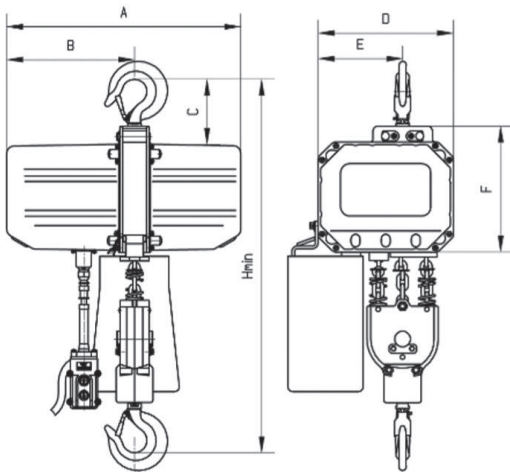

HHXG43TS — 3BHX

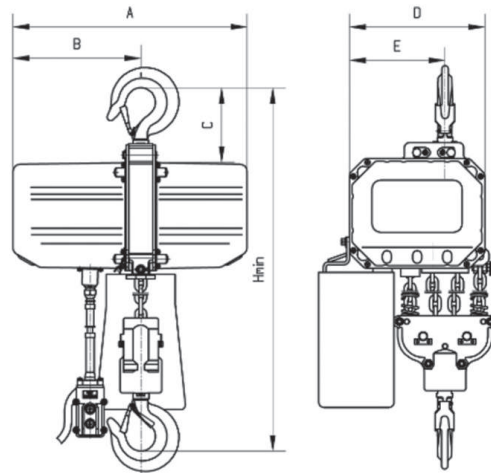

HHXG44NS — 5BHX

Available in 20' lifts

Prod. No.	107502	107503	107504	107505	107506
Rated Capacity (Ton)	1/2	1	2	3	5
Hoisting Speed (fpm)	19.7	19.7	9.8	6.6	4.9
Headroom (in.)	20.16	24.41	28.15	31.50	30.71
Motor	.87HP, 115/230V 60Hz		1.75 HP, 115/230V 60Hz		
Duty Cycle Rating*	15 min/hr				
No. of Falls	1	1	2	3	4
Net Weight (lbs.)	119.05	171.96	187.39	227.08	257.94
A (mm)	450	519	519	519	519
B (mm)	576	695	715	952	977
C (mm)	352	386	386	386	386
D (mm)	260	300	300	300	300
E (mm)	334	403	403	403	403

The above specifications were current at the time this manual was published, but because of our policy of continuous improvement, JET® reserves the right to change specifications at any time and without prior notice, without incurring obligations.

SPECIFICATIONS — THREE PHASE

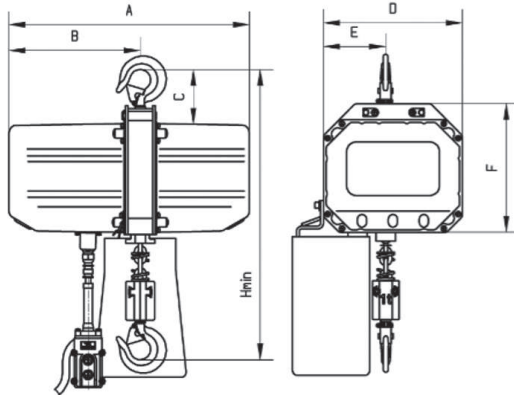

HHXG31FS — 1/2BH, HHXG41ES — 1BH

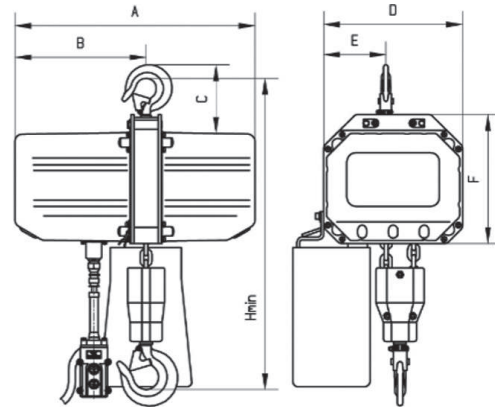

HHXG42BS — 2BH

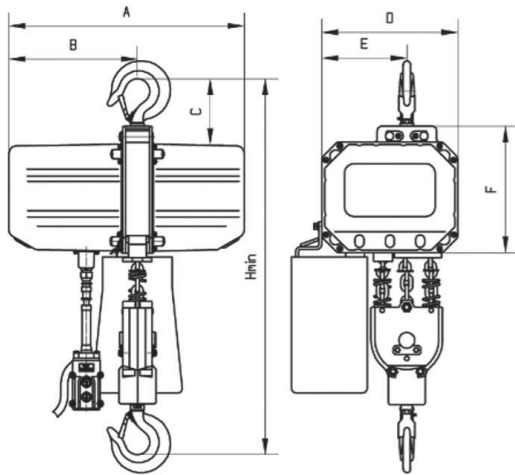

HHXG43TS — 3BH

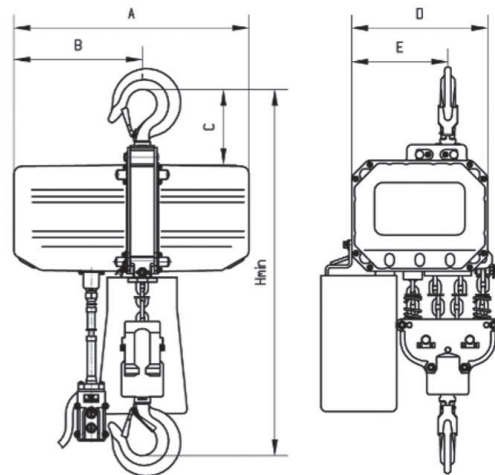

HHXG44QS — 5BH

Available in 20' lifts

Prod. No.	107513	107514	107515	107516
Rated Capacity (Ton)	1	2	3	5
Hoisting Speed (fpm)	24.80	12.40	8.30	6.30
Headroom (in.)	24.41	28.15	31.50	30.71
Motor	2.17 HP, 230/460V 60Hz			
Duty Cycle Rating*	15 min/hr			
No. of Falls	1	2	3	4
Net Weight (lbs.)	160.94	176.37	216.05	264.55
A (mm)	519	519	519	519
B (mm)	695	715	952	977
C (mm)	386	386	386	386
D (mm)	300	300	300	300
E (mm)	403	403	403	403

The above specifications were current at the time this manual was published, but because of our policy of continuous improvement, JET® reserves the right to change specifications at any time and without prior notice, without incurring obligations.

UNPACKING

Open the shipping container and check for shipping damage. Report any damage immediately to your distributor and shipping agent. Do not discard any shipping material until the Chain Hoist is installed and running properly.

Missing parts, if any, should be reported to your distributor. Read this owner's manual thoroughly for assembly, maintenance, and safety instructions.

Contents of the Shipping Container

- 1 Electric Chain Hoist
- 1 Chain Container with Bracket and fasteners
- 1 Power Cord
- 1 Pendant Cord
- 1 Top Hook Assembly
- 1 Owner's Manual
- 1 Load Test Certificate

INSTALLATION

Support for the hoist may be a hook, clevis pin, trolley, or beam clamp. Whatever method of suspension is chosen, the support components must be rated equal to, or greater than the capacity of the chain hoist. Supporting structures (such as I-Beams, etc.) should be installed by properly licensed professional installers.

Installing Top Hook

1. Remove the two screws, lock washers and flat washers (A, Figure 1), the hook-pin plates (B) and the hook pins (C).
2. Place the top hook assembly (D) into position between the body plates, and re-install pins, hook-pin plates, screws, and washers. Firmly tighten the screws.
3. Place the hoist assembly into position on the supporting structure.

If you are using the hoist with a trolley, refer to the trolley manual for instructions on securing the pendant cord and maintaining proper slack in the cord during operation.

Installing Power and Pendant Cords

NOTE: If you need to convert the voltage requirements of the hoist, it will be more convenient to do that now before installing the power cord or pendant cord. See "Voltage Conversion" on page 9.

1. Attach the power cord and pendant cord to the cable holder, as follows:

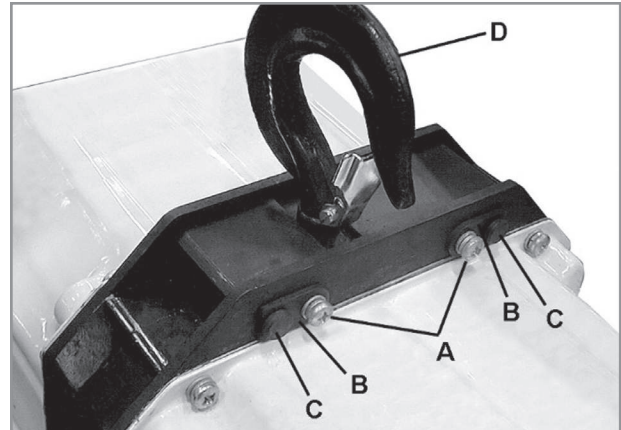

Figure 1

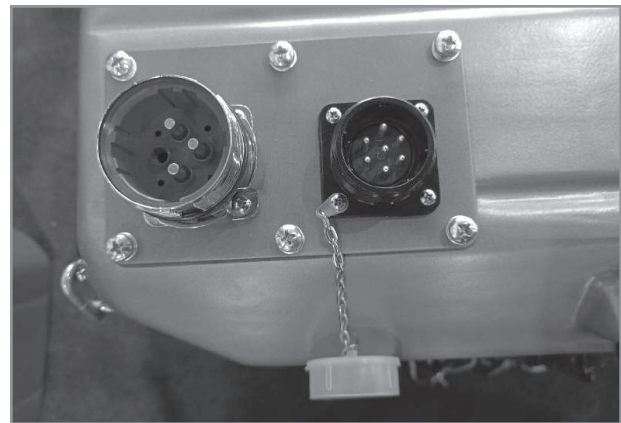

Figure 2

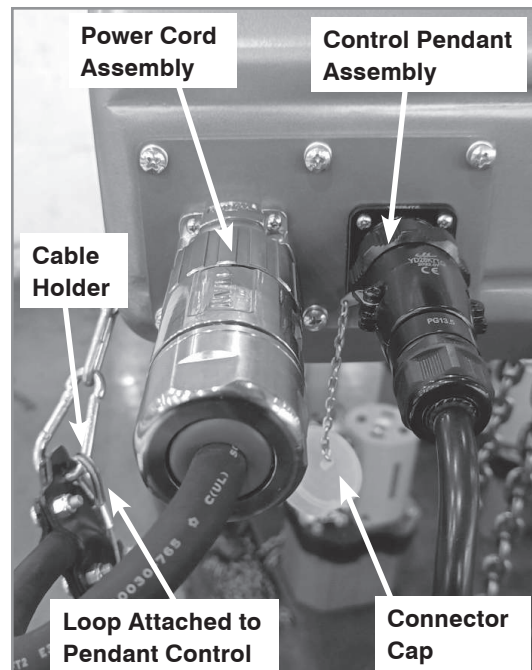

Figure 3

2. Open the connector caps on the two female connectors (Figure 2) and two male plugs (Figure 3).
3. Check the orientation of notches on the female connectors and male plugs, correctly insert the 4p plug into the 4p female connector on the left and insert the 7p plug into the 7p female connector on the right with sufficient force (see Figure 3).
4. Tighten the two cover nuts with fingers (see Figure 4).

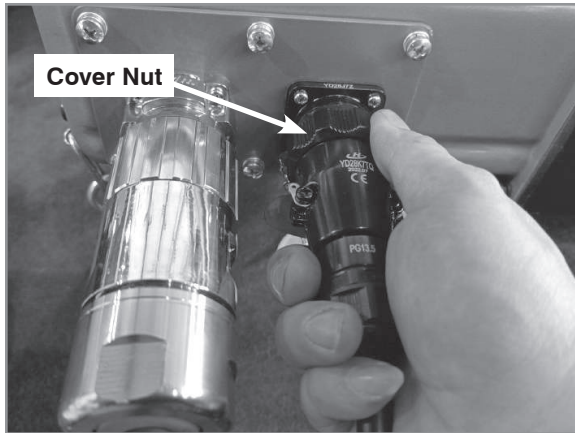

Figure 4

ELECTRICAL INSTRUCTIONS

⚠ WARNING Electrical connections must be made by a qualified electrician in compliance with all relevant codes. This machine must be properly grounded to help prevent electrical shock and possible fatal injury.

Grounding

In the event of a malfunction or breakdown, grounding provides a path of least resistance for electric current to reduce the risk of electric shock.

This machine's power cord must be fitted with an appropriate UL/CSA listed plug, or it can be "hard-wired" directly to a control panel. If hard-wired, make sure a disconnect is available for the operator.

If a plug is installed, it must have an equipment-grounding conductor and a grounding prong. The plug must be plugged into a matching outlet that is properly installed and grounded in accordance with all local codes and ordinances. Do not modify the plug — if it will not fit the outlet, have the proper outlet installed by a qualified electrician.

Improper connection of the equipment-grounding conductor can result in a risk of electric shock. The conductor with insulation having an outer surface that is green with or without yellow stripes is the equipment-grounding connector.

If repair or replacement of the electric cord or plug is necessary, do not connect the equipment-grounding conductor to a live terminal.

Check with a qualified electrician or service personnel if the grounding instructions are not completely understood, or if in doubt as to whether the tool is properly grounded.

Repair or replace damaged or worn cord immediately.

Voltage Conversion

The **single-phase JEH models** are designed for 115-volt or 230-volt operation. They are pre-wired for 230 volts. To change to 115V proceed as follows:

1. Disconnect the hoist from the power supply and unplug the power cord and pendant cord from the hoist
2. Remove the motor cover and move the plug from the 230V socket to the 115V socket.
3. Re-install the motor cover.

The **three-phase JEH models** are designed for 230-volt or 460-volt operation. They are pre-wired for 460V. To change to 230V proceed as follows:

1. Disconnect the hoist from the power supply and unplug the power cord and pendant cord from the hoist.
2. Remove the motor cover and move the plug from the 460V socket to the 230V socket.
3. Re-install motor cover.

Refer to the diagrams at the back of this manual for any clarification of these procedures.

NOTE: When connecting plug to socket, check that the connector notch is fully engaged. To remove a plug, press on the notch tail to disengage notch.

Inspecting Hoist Motion

1. Before closing the circuit breaker and testing the hoist, check that wiring has been completed. If the hoist cannot be observed when the circuit breaker is closed, station an observer within sight of the hoist to report any movement when power is applied to the hoist. Be prepared to disconnect power if hoist motor starts when the power is applied. The hoist must remain motionless when power is applied. Find and correct any problems before continuing.
2. With no load on the load hook, press the UP button very briefly and observe hoist action. The hook should move upward.
3. If no motion occurs when the UP button is pressed and the hoist is connected to a three-phase power supply, the power supply wires are incorrectly positioned. Switch any two of the three supply wires at the power source. **Do not attempt to rewire the hoist circuit or pendant controls for this problem.** Use the same safety precautions when

reversing two of the supply wires as was used when the wires were originally connected.

4. Re-connect power and test hoist movement again without load. Run hoist to the complete lifting height to ensure limit switches are operating properly.

Extension Cords

If an extension cord is necessary, make sure the cord rating is suitable for the amperage listed on the hoist's motor plate. An undersized cord will cause a drop in line voltage resulting in loss of power and overheating.

The chart in Figure 5 shows the correct size cord to use based on cord length and motor plate amp rating. If in doubt, use the next heavier gauge. The smaller the gauge number, the heavier the cord.

Recommended Gauges (AWG) of Extension Cords

Amps	Extension Cord Length*					
	25 feet	50 feet	75 feet	100 feet	150 feet	200 feet
< 5	16	16	16	14	12	12
5 to 8	16	16	14	12	10	NR
8 to 12	14	14	12	10	NR	NR
12 to 15	12	12	10	10	NR	NR
15 to 20	10	10	10	NR	NR	NR
21 to 30	10	NR	NR	NR	NR	NR

*Based on limiting the line voltage drop to 5V at 150% of the rated amperes.

NR: Not Recommended

Figure 5

Installing Chain Container

Your hoist is supplied with a canvas chain container (Figure 6) designed to fit the particular length of chain. If a different length chain is ever installed on this hoist, the chain container must be replaced by one of proper size. See chart on page 19.

⚠ WARNING Do not overfill chain container. If the chain should overfill and begin to fall, the entire chain container may empty without warning, resulting in serious personal injury or property damage.

To assemble the chain container to the hoist:

1. Hang hoist in position on the I-Beam or trolley. Do not install the chain container yet. Allow slack side and load side of chain to hang freely from the hoist.
2. Apply power to the hoist and press the DOWN button until the lower limit switch is tripped.

3. Check the chain container to ensure that the seam is inside the bag. The bag must not be inside out.
4. Insert bracket prongs into interior bag slots (Figure 6) as far as they will go.



Figure 6

5. Push the bracket down into the bag making sure the flaps are raised (Figure 7).
6. Push the flaps over and down until they are secure (Figure 8)



Figure 7



Figure 8

7. Remove the screw and washer holding the end chain to the hoist (Figure 9). Mount the bracket of the chain container in that location as shown in Figure 10.
8. Put the chain stop into the container (Figure 10) and operate the hoist to bring the load hook up until the upper limit switch is tripped.
9. Check the chain to ensure that all the non-loaded chain is completely in the container.

⚠ CAUTION Do not put chain into the chain container by hand! By not following the above steps, the chain can become twisted or kinked and can damage the hoist.

PRE-OPERATION INSPECTION

Inspecting the Load Chain

Clean the chain with a solvent and carefully inspect the entire load chain. Replace damaged chain before using the chain hoist. See “Inspection Procedures: Allowable Limits” on page 17 for the maximum pitch allowed for chain length. If the chain exceeds this amount, it must be replaced.

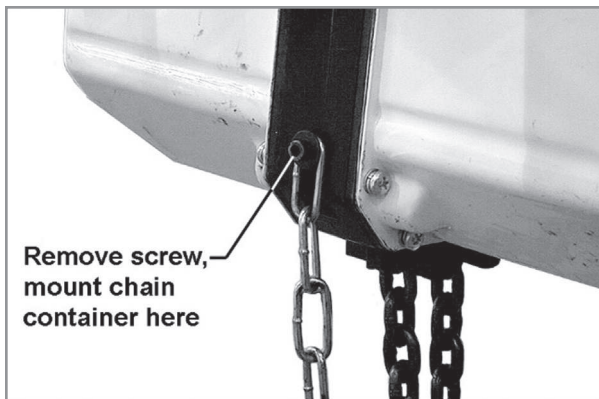

Figure 9

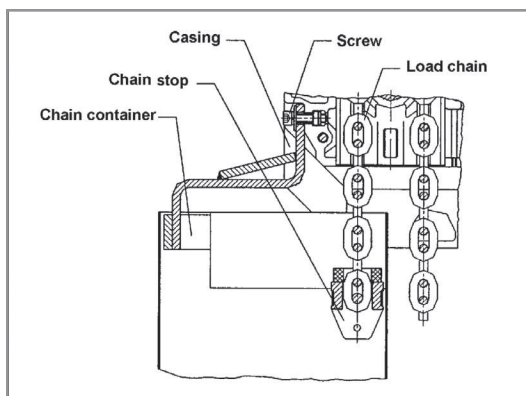

Figure 10

Also replace the load chain if any of the following are identified:

1. Seriously rusted or cracked.
2. Marks on the chain surface are deeper than 5% of the link's diameter.
3. Links are twisted or deformed.
4. The links are stretched too long or seriously worn on the surface, especially at the points where links contact each other.

Never extend load chain by welding a second piece to the original.

⚠ WARNING Do not operate the hoist with a twisted, kinked, or damaged load chain. Do not splice the load chain.

Check that the chain does not twist along its length from hoist to hook. If twist is present on units with multiple falls, the hook must be passed back through the chain loop to remove all twists in the chain.

⚠ WARNING The load chain supplied with your JET® JEH chain hoist is designed, manufactured, and tested for proper fit and durability. Over a period of time, the chain may need to be replaced. For your own safety, use factory replacement chain only. Use of other than factory replacement chain may cause serious injury and/or damage to the hoist.

A light coat of 30-weight oil applied periodically to the chain will create easier operation and prolong the life of the chain.

Inspecting the Hooks

It is important to check top and bottom hooks for proper opening and other signs of deformation or damage. Replace a hook immediately if any of the following problems are identified:

1. The safety latch no longer contacts the hook opening.
2. The vertical angle at the neck of the hook reaches 10° (see Figure 11).

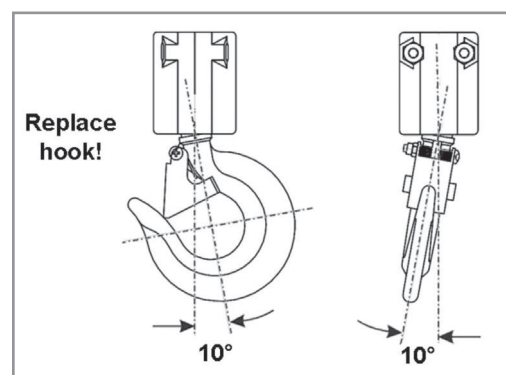

Figure 11

3. Chemical corrosion or cracks on the hook.
4. Excessive wear on the inside surface.
5. The throat opening has enlarged. (See page 17 for the maximum allowable limits for the throat opening.)

NOTE: Excessive hook throat opening or twist indicates abuse or overloading of the hoist. If such deformation

is discovered, inspect hoist, chain and all supporting members very carefully for additional indications of excessive hoist loading.

⚠ WARNING Do not attempt repair of a hook by heat treating, bending or attaching anything by welding. Such procedures will weaken and may cause failure of the hook.

OPERATING THE HOIST

Allow the hoist to come to a full stop before changing direction. Rapidly reversing or catching a falling load can overload the hoist system and cause a failure in the hoist and/or chain, resulting in injury or property damage.

If the hoist is connected to a manual trolley, move the hoist by pushing on the suspended load. Move an unloaded hoist by pulling on the empty hook. Do **NOT** move the hoist by pulling on the pendant cord.

The brake mechanism must be kept clean and free from dirt, water, and oil. Never allow oil to penetrate the brake mechanism. Always keep your hoist clean, and store in a clean, dry location.

Follow this general procedure for hoisting loads:

1. Secure the upper hook to the supporting structure.
2. Place load sling or chain in the centre of the bottom hook, making sure the safety latch is secure. **Never load the hook in front of the safety latch.** See Figure 12.
3. Avoid lifting one load with two hoists. If this is unavoidable, apply equal weight to both hoists and use hoists with the proper lift capacity. **Capacity of each hoist must be equal to the total load to be lifted.**
4. Press the UP button and remove all slack in the load chain. Increase tension in the load chain until the hoist is about to raise the load.
5. Check again that the load is properly slung, directly under the hoist, and will not suddenly swing or twist.
6. Raise the load an inch or two above the ground and stop. Observe load for a few moments, looking for signs that the load or hoist system is unstable, or other indications that there is a problem.
7. Check that the chain is not twisted at the bottom hook. All welds should face the same direction (see Figure 14). For hoists with two or more falls of chain, make sure the bottom hook is not turned over. This may cause the chain to twist.
8. Raise load to the travelling height. Raise only to the height necessary to safely clear all obstacles.
9. Lower load at destination. If both UP and DOWN commands must be used during lowering, pause for a moment between each reversal of load direction.
10. Slowly allow weight to shift from hoist to ground or new support. Do not approach load until all tension is out of the chain and the load is stable.

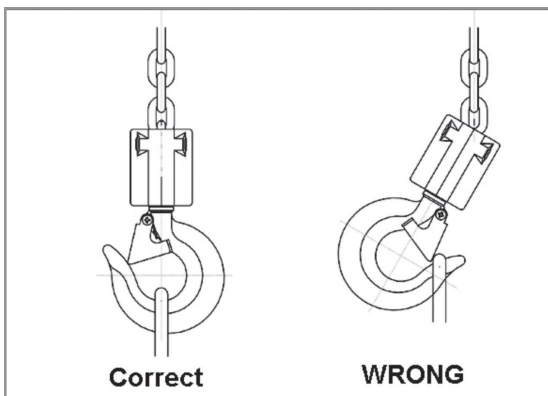

Figure 12

ADJUSTMENTS

Safety Clutch Adjustment

The load limit of the safety clutch has been set to within 1.3 to 1.8 times the rated load of the hoist. Generally, the safety clutch will not require adjustment. But if the hoist ever fails to lift the rated load while the rotor is turning, the safety clutch must be re-adjusted. Proceed as follows (see Figure 13):

1. Suspend the rated load in the bottom hook.
2. Push the UP button to create tension on the load chain, but do not raise the load off the ground.
3. Disconnect the power source and remove the gear side cover.
4. Loosen the screw (G), open the plate (J), and push down the adjusting shaft (K) until it fully engages the adjusting circle nut (L). Rotate the nut (H) clockwise to tighten the adjusting circle nut (L).
5. Pull the adjusting shaft (K) out of engagement with the adjusting circle nut (L). Then close the plate (J) and tighten screw (G).
6. Connect hoist to power source and push the UP button on the pendant control. The hoist should now lift the rated load. If it will not lift the load, disconnect power and repeat steps 4 and 5 to tighten the adjusting circle nut until it can lift the rated load.
7. Now change the load to within 1.3 to 1.8 times the rated load, then push the UP button. The hoist should NOT be able to lift the load. If it can lift the load, repeat steps 4 and 5, rotate the adjusting nut (H) and loosen the adjusting circle nut (L) until the hoist cannot lift the load.
8. Unload the hoist and repeat step 6 with the original rated load. The hoist should now be able to lift the original rated load. If it does not, repeat steps 6 and 7 until the hoist operates with the rated load only, but not with the 1.3 to 1.8 times rated load.
9. Unload the hoist and re-install the gear side cover.

Replacing Load Chain

Over time, the load chain will wear or elongate. This can cause damage to the hoist, breakage, or non-engagement of the load sheave. The following procedures describe replacing the load chain for single and multiple fall hoists.

These procedures should be performed by experienced personnel only.

How to Cut Chains

Use a bolt cutter with special cutter jaws for cutting hardened chain. Cut only one side of the link at a time. When making the second cut, place a mat over the chain to catch the flying chain section.

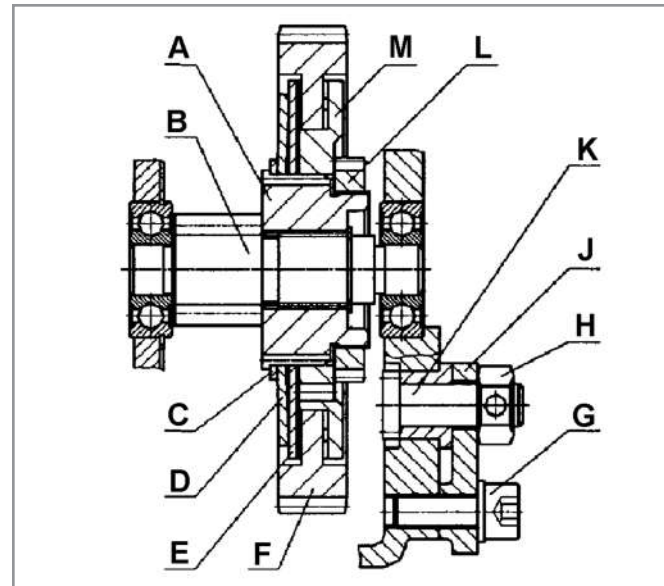

- | | |
|------------------------|--------------------------|
| A — Spline hub | G — Screw |
| B — First stage pinion | H — Adjusting nut |
| C — Adjusting washer | J — Adjusting plate |
| D — Dish spring | K — Adjusting shaft |
| E — Clutch friction | L — Adjusting circle nut |
| F — First stage gear | M — Clutch carrier |

Figure 13

Making a C-Link

Replacing load chain will require the use of a C-link (in some cases, two C-links), which you can easily make as follows:

1. Cut a link from the old chain.
2. Cut the weld from the link leaving an opening approximately 1.25 times the diameter of the link material. See Figure 14.
3. Grind the cut areas smooth and remove all burrs.

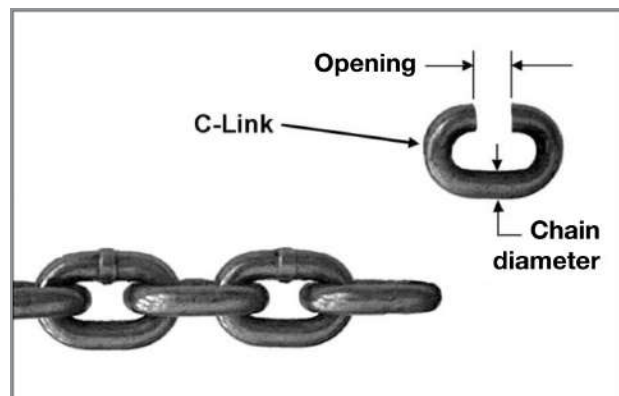

Figure 14

Single Fall Chain Hoist

1. Lower the load hook until only 1 to 2 feet of slack chain remains in the chain container.
2. Remove chain container.
3. On the slack side of the chain, remove the chain stop and the spring (Figure 15). Keep these handy for later re-installing.
4. Using a C-link, connect the new chain to the old chain. Be sure vertical link welds face away from load sprocket (see Figure 16).
5. Keep tension on both sides of the chain and lower the load hook to pull the new chain through the hoist. Do not let the chain twist or bind as it is being pulled through the hoist.

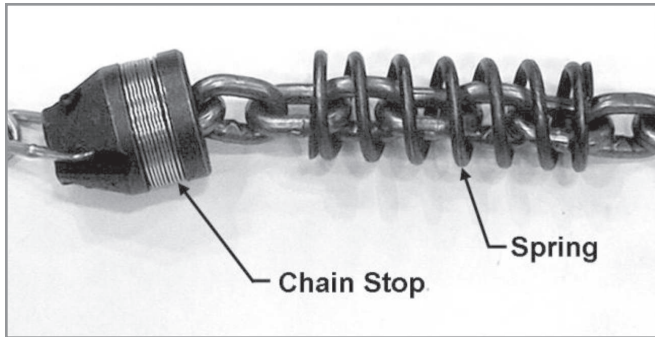

Figure 15

6. Stop hoist when 1 to 2 feet of new chain remains on the slack side.
7. Install the spring and chain stop on the slack end of the chain.
8. Remove the load hook and the spring from the old chain and install them on the new chain. Inspect the condition of both spring and hook.
9. Lower load hook until the limit switch stops hoist movement. Inspect the chain for any signs of twist.
10. Install the chain container following the instructions in this manual. Do not fill the chain container by hand.
11. It is recommended that after installing new chain the first few lifts be limited to no more than 25–50% of the rated load. Thoroughly Inspect the chain for twist before placing hoist in routine service.

Vertical and Horizontal Links

Vertical and horizontal are determined from the relationship with the load sprocket. Vertical links will be guided by the centre slit in the load sprocket. Horizontal links will engage in the oval pockets on the sprocket. See Figure 16.

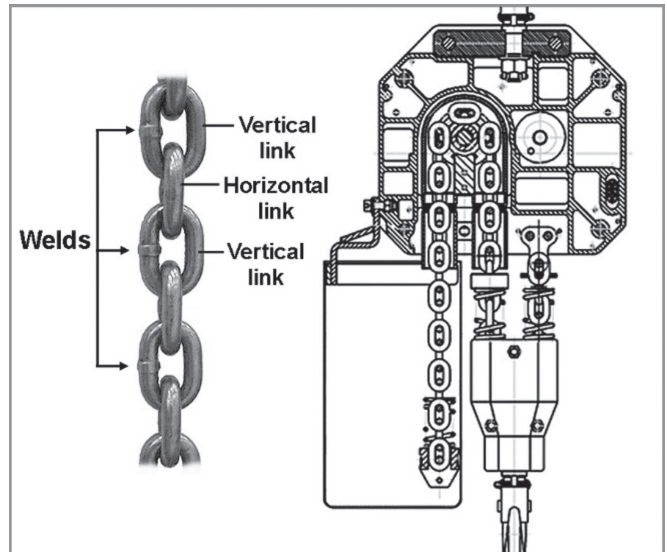

Figure 16

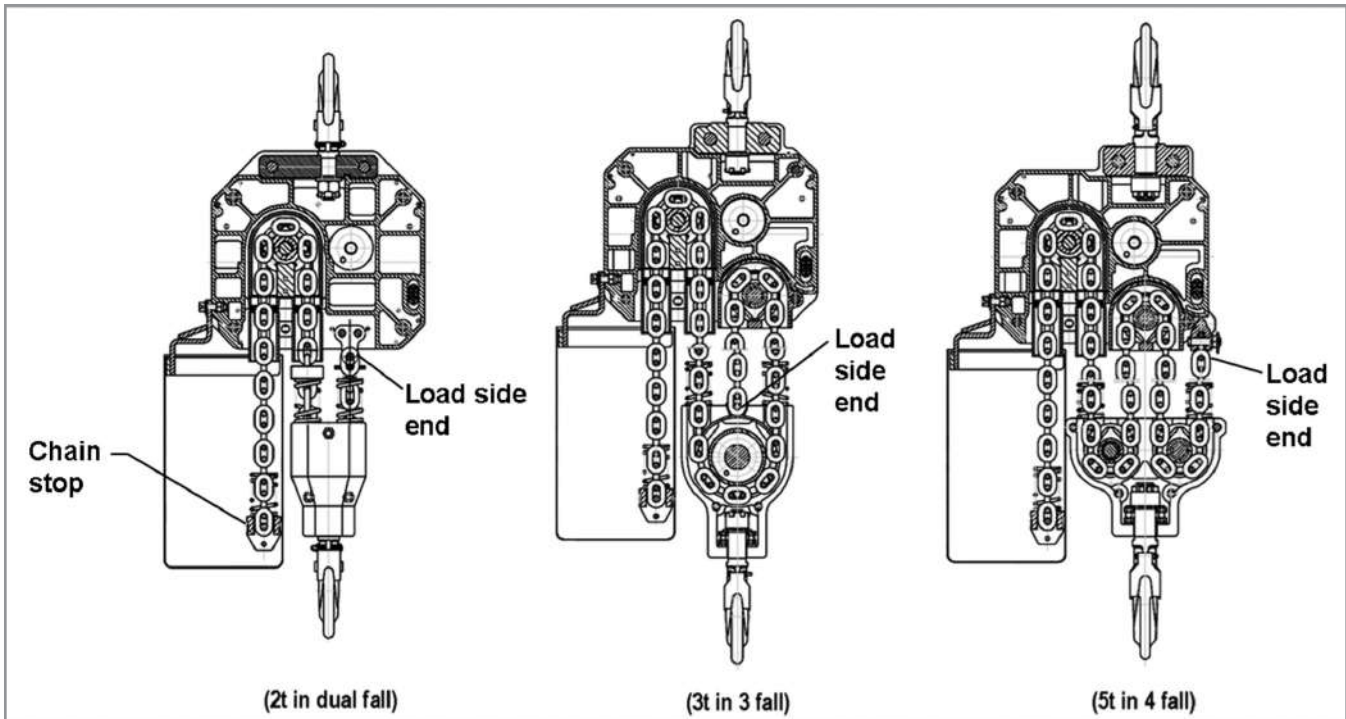

Figure 17

Dual/Multiple Fall Chain Hoists

CAUTION The link on the load side end must be a vertical link. If it is a horizontal link, the chain will have a twist in it.

1. Lower hook until only 1 to 2 feet of slack chain remains in the chain container.
2. Remove chain container.
3. On the slack side of the chain, remove the chain stop, and remove the black spring(s). (see Figure 15). Keep these handy for later re-installing.
4. Using a C-link(s), connect the new chain to the old chain. If the end link of the old chain is horizontal, use two C-links. If the end link of the old chain is vertical, use one C-link See Figure 18. Using the correct number of C-links will properly orient the chain and ensure that the first link on the load side end is a vertical link.
5. Install the spring(s) and chain stop on the opposite end of the new chain.
6. Support the load hook so that the load chain can pass through the chain sheaves smoothly. Figure 17 shows the load chain path for the various sizes of hoists.
7. Press the DOWN button to move the chain through the hoist. Keep tension on the chain as you pull it through to the load side until the C-link(s) clears the hoist at the load side.

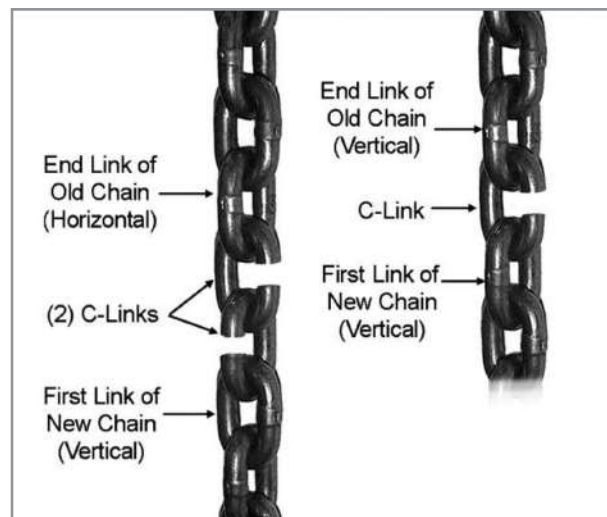

Figure 18

8. Place the first link of the new chain into the load side end holder. Be sure that there is no twisted chain between the last chain sprocket and the load side end holder.
9. Remove the chain stop bolt from the old chain and install it on the new chain. Do not substitute any other bolt in this application. Use a new cotter pin to secure the bolt.
10. Install the chain container following the instructions in this manual. Do not fill the chain container by hand.

11. Lower hook until limit switch stops hoist movement, then raise hook until limit switch stops hoist movement. Inspect chain for any signs of twist and correct before continuing.
12. It is recommended that the first few lifts be limited to no more than 25-50% of the rated load. Inspect chain for twist before placing hoist into routine service.

Brake Adjustment

The normal gap between the armature and the iron core is from 0.5 mm to 1.0 mm. If the gap is out of the range of 0.5 mm to 1.0 mm, it must be adjusted as follows (see Figure 19):

1. Disconnect the hoist from the power source.
2. Remove the gear side cover.
3. Remove the locking plate (H) by unscrewing the four screws (J).
4. Insert a 0.5 mm spacer between the iron core (K) and the armature (B).
5. Tighten the four nuts (G) by an equal amount one by one. The gap is now adjusted to 0.5 mm.
6. Release the four nuts (G) by 1/6 of a turn and remove the spacer. Re-tighten each of the nuts by 1/6 of a turn.
7. Re-position the locking plate (H) and install the four screws (J).
8. Re-install the gear side cover.

NOTE: When adjusting the brake, if the brake pad is found deformed, the glue has failed, or the lining is severely worn, the brake pad should be replaced. See page 18.

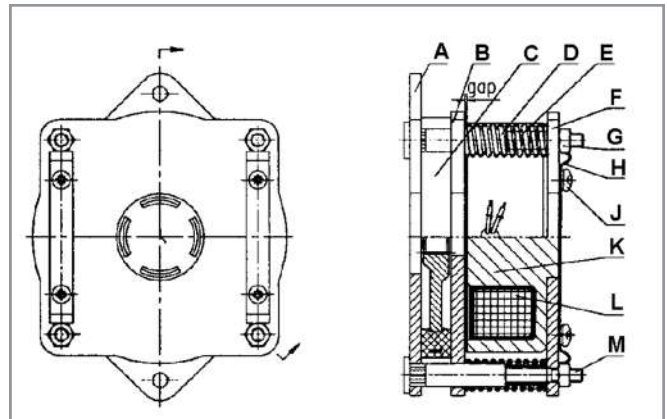

- | | |
|------------------------------|-------------------|
| A — Base plate | G — Nut |
| B — Armature | H — Locking plate |
| C — Brake pad | J — Screw |
| D — Brake spring | K — Iron core |
| E — Location spring | L — Brake coil |
| F — Iron core locating board | M — Brake screw |

Figure 19

INSPECTION AND MAINTENANCE

⚠ WARNING All repairs and adjustments are to be performed by trained and experienced personnel using procedures that are approved for the hoist system being serviced. All safety-related deficiencies discovered in the inspection are to be corrected before the hoist is placed back in service. Check for internal damage whenever external damage has occurred.

Read and follow the ANSI Inspection and Maintenance instructions. Know the meaning of Frequent Inspection, Periodic Inspection, Normal Service, Heavy Service, and Severe Service. It is the customer's responsibility to understand and follow all ANSI and this inspection and maintenance instructions.

The following items are to be inspected by appointed personnel at the time interval noted below. Dated inspection and repair reports must be maintained. Copies of all reports must be available to service personnel.

Inspection Schedule A

Service Interval:

Normal Service — Monthly

Heavy Service — Weekly to Monthly

Severe Service — Daily to Weekly

1. Check brake for slippage.
2. Check that pushbutton controls operate properly.
3. Check that limit switches function properly. Without load, operate the up-button control while observing stopper spring. If stopper spring becomes compressed and motor does not stop, STOP operation immediately. The limit switch is not operating properly. Repeat test with down button control.
4. Check top hook and load hook for deformation, chemical damage, and cracks.
5. Check that the load chain is clean and lightly lubricated, free of excessive wear or deformation at the contact points between links and link and hook. This hoist uses a special alloy hoisting chain and does not interchange with any other manufacturer. All replacement chain must be purchased from your JET® distributor or JET Equipment & Tools LTD.
6. Check that the chain passes through all sprockets smoothly while under load.
7. Check the entire hoist system for signs of damage and loss of integrity.

Inspection Schedule B

Service Interval:

Normal Service — Yearly

Heavy Service — Semi-Annually

Severe Service — Quarterly

1. Do all Schedule A items.
2. Check the entire unit for loose screws, bolts, nuts, and pins.
3. Check for evidence of excessive wear, corrosion, cracks, or distortion in the following parts: hook parts, chain attachments, suspension bolts and shafts, gears, bearings, pins, rollers, and locking and clamping devices.
4. Check for evidence of damage to hook parts including hook retaining nuts and collars and pins and hook holding frame and parts used to secure the frame.
5. Check for evidence of damage or excessive wear of load gear, sheave and sprocket wheel. If the pockets are too deep, the chain may jam with a corresponding failure of engagement between chain and sprocket or sheave.
6. Check for evidence of excessive load brake wear. Inspect clearance between brake components and adjust if needed.
7. Check for evidence of pitting or other deterioration of visible controller contacts.
8. Check for evidence of deterioration of supporting structures and trolleys.
9. Check for visible deformation of limit switch coil springs.
10. Check that all warning labels are present and readable.

INSPECTION PROCEDURES: ALLOWABLE LIMITS

Load Chain

Carefully inspect the entire load chain. Measure five consecutive links with calipers in the manner shown in Figure 20. Check every three feet and especially where excessive wear is indicated. Any load chain that shows noticeable deformation or heat influence must be replaced with a new one. Never extend load chain by welding a second piece to the original.

Capacity	Load Chain	5 Links Normal	5 Links Limit
1/2 ton	6.3 x 19 mm	3.74"	3.8"
1 ton	8 x 24 mm	4.72"	4.79"
2 ton	8 x 24 mm	4.72"	4.79"
3 ton	8 x 24 mm	4.72"	4.79"
5 ton	8 x 24 mm	4.72"	4.79"

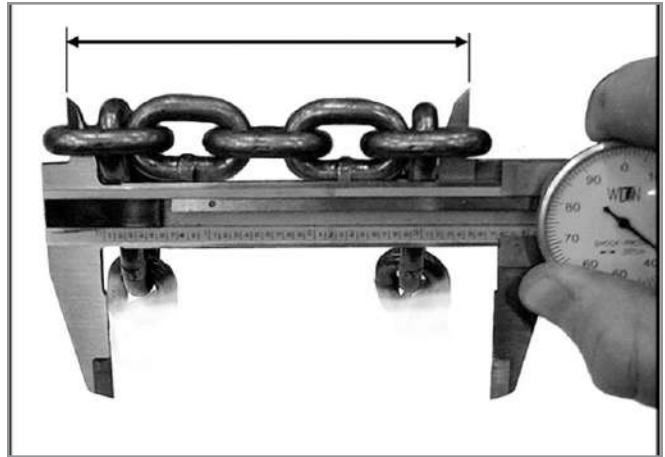

Figure 20

Hooks (Top and Bottom)

Replace the hook when the "A" or "B" measurement, as shown in Figure 21, reaches the limit shown in the tables below. Never heat treat the hook or attach anything to the hook by welding.

NOTE: Excessive hook throat opening or twist indicates abuse or overloading of the hoist. If such deformation is discovered, inspect the hoist, chain and all supporting members very carefully for additional indications of excessive hoist loading.

Throat — "A"

Capacity	A — Normal	A — Limit
1/2 ton	1.26"	1.386"
1 ton	1.42"	1.562"
2 ton	1.73"	1.903"
3 ton	1.73"	1.903"
5 ton	1.97"	2.167"

Seat — "B"

Capacity	B — Normal	B — Limit
1/2 ton	1"	under 0.9"
1 ton	1.15"	under 1.035"
2 ton	1.56"	under 1.404"
3 ton	1.56"	under 1.404"
5 ton	1.78"	under 1.602"

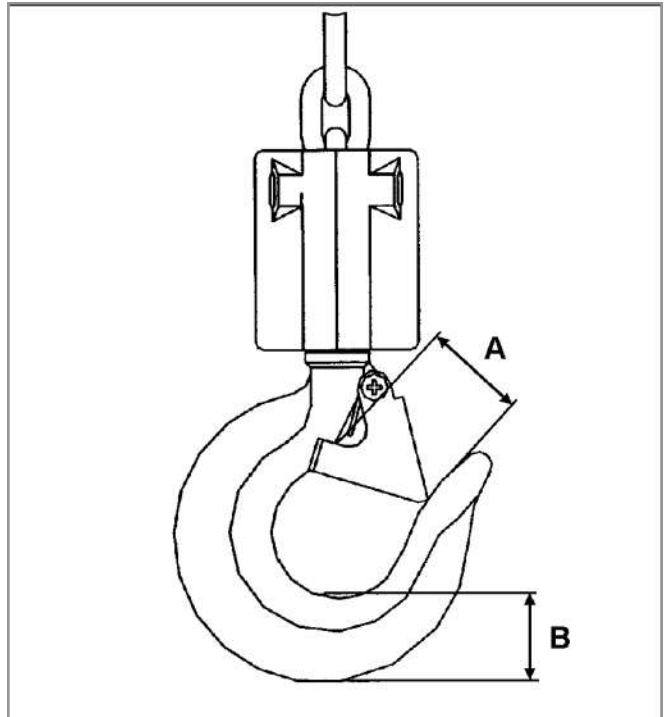

Figure 21

Brake Friction Pad

See Figure 22.

Before suspecting or replacing the brake friction pad, make sure the brake and the safety clutch have both been adjusted properly according to the instructions on pages 13 and 16.

If the friction pad is suspect, measure its thickness using a caliper. If it is under the thickness limit, replace it according to the chart below.

Capacity	Thickness Normal	Thickness Limit (replace)
1/2 ton	0.51"	under 0.48"
1 ton	0.59"	under 0.55"
2 ton		
3 ton		
5 ton		

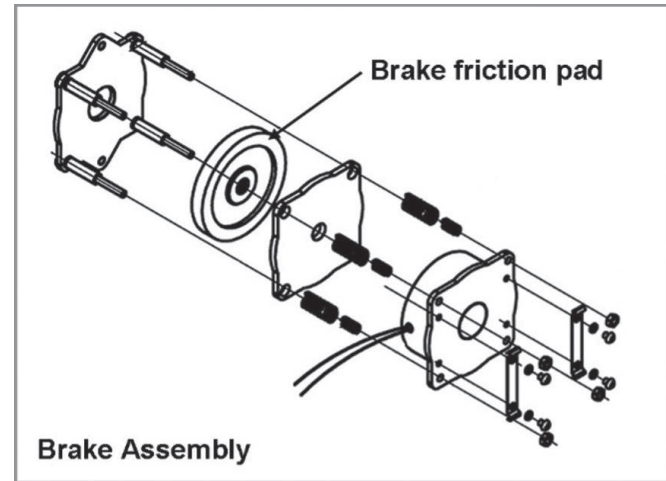

Figure 22

⚠ WARNING Do not attempt to rebuild a worn friction pad and do not modify brake system in order to use a worn-out pad.

CHAIN CONTAINER CHART FOR STANDARD OR CUSTOM LIFTS

Description	Hoist Model	Lift (m/ft)																	
		3 m (10')	4 m (13')	5 m (16')	6 m (20')	7 m (23')	8 m (26')	9 m (30')	10 m (33')	11 m (36')	12 m (40')	13 m (43')	14 m (46')	15 m (49')	16 m (53')	17 m (56')	18 m (59')	19 m (63')	20 m (66')
1/2-T in single and three phase	107502	A	A	A	A	A	A	A	A	A	A	C	C	C	C	C	C	C	C
1-T in single and three phase	107503 107513	B	B	B	B	B	B	B	B	B	B	D	D	D	D	D	D	D	D
2-T in single and three phase	107504 107514	B	B	B	B	D	D	D	D	D	D	E	E	E	E	-	-	-	-
3-T in single and three phase	107505 107515	B	B	D	D	D	D	E	E	-	-	-	-	-	-	-	-	-	-
5-T in single and three phase	107506 107516	B	D	D	D	E	E	-	-	-	-	-	-	-	-	-	-	-	-

A = Chain Container part no. PZG-JEH12S-63
 B = Chain Container part no. PZG-JEH1S-63
 C = Chain Container (special order) PZG-JEH-63C
 D = Chain Container part no. PZG-JEH3-63
 E = Chain Container (special order) PZG-JEH-63D

TROUBLESHOOTING

Trouble	Probable Cause	Remedy
Motor will not run.	No incoming power, or low voltage.	Check hoist connections to power source. If low voltage, have a certified electrician check incoming power.
	Fuse blown or circuit breaker tripped.	Replace fuse/reset circuit breaker.
	Rectifier damaged in the phase protector so the brake won't work.	Replace phase protector.
	Transformer damaged.	Replace transformer.
	Motor damaged.	Have motor replaced by a qualified service technician.
Hoist lifts but will not lower.	Broken conductor in pendant cord.	Test continuity of each conductor. Replace cable if needed.
	Up/down switch malfunctioning.	Repair or replace switch.
Hoist lowers but will not lift.	Overloaded.	Reduce load to within hoist capacity.
	Up/down switch malfunctioning.	Repair or replace switch.
	Clutch malfunction.	Have clutch replaced by qualified personnel.
Load continues drifting down excessively when hoist is stopped.	Grease or oil on the lining.	Open the hoist, disassemble the brake and clean the lining.
	Disc brake is worn.	Adjust clearance between armature and iron core. See page 16.
	Brake springs are damaged.	Replace brake springs.
Hoist moves in wrong direction.	Two of the three power supply wires are switched.	Switch any two of the three supply wires (see pages 9 and 10).
Motor overheats.	Excessive load or too frequent use.	Operate within rated load and according to duty cycle rating.
	Brake drags.	Adjust brake clearance (see page 16).
Poor engagement of chain with sprocket/sheave.	Load chain is seriously worn.	Replace load chain. See pages 12, 13, 14, and 15.
	Sprocket wheel, sheave or chain guide is seriously worn.	Replace parts as needed.
Will not lift rated load.	Overload limit clutch friction torque too low.	Readjust the overload clutch to proper limits (qualified personnel only).
	Overload limit clutch damaged.	Replace overload limit clutch.
Limit switch failure.	Bad connection of limit switch leads.	Inspect the contacts of the leads and limit switches.
	Limit switch damaged.	Replace limit switch.

1/2-TON CHAIN HOIST — PARTS BREAKDOWN — Prod. No. 107502

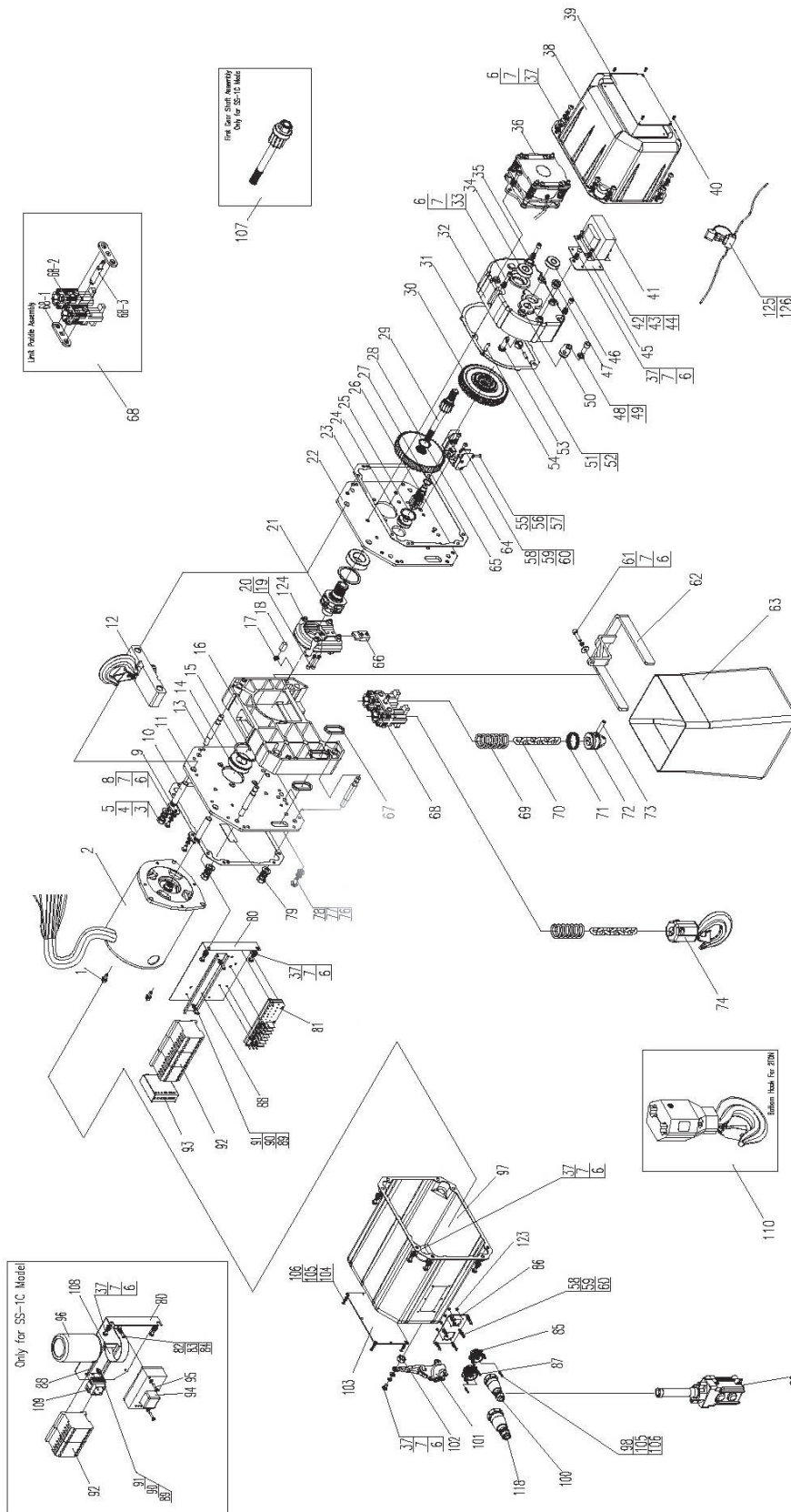

PARTS LIST: 1/2-TON CHAIN HOIST — REPLACEMENT PARTS — Prod. No. 107502

REF	PART NUMBER	DESCRIPTION	REQ	REF	PART NUMBER	DESCRIPTION	REQ
01	PZG-JEH12S-01	MOTOR STAY BOLT (INCLUDES LOCK WASHER, PLAIN WASHER) M8X16	3	43	PZG-JEH12S-43	LOCK WASHER 4 MM	4
02	PZG-JEH12S-02	MOTOR ASSEMBLY FOR 1-PHASE	1	44	PZG-JEH12S-44	PLAIN WASHER 4 MM	4
03	PZG-JEH12S-03	HEX NUT M10	8	45	PZG-JEH12S-45	TRANSFORMER BRACKET	1
04	PZG-JEH12S-04	LOCK WASHER 10 MM	8	46	PZG-JEH12S-46	BALL BEARING 180201KZ1	1
05	PZG-JEH12S-05	PLAIN WASHER 10 MM	8	47	PZG-JEH12S-47	STEEL COLLAR	1
06	PZG-JEH12S-06	PLAIN WASHER 6 MM	30	48	PZG-JEH12S-48	PLAIN WASHER 8 MM	1
07	PZG-JEH12S-07	LOCK WASHER 6 MM	30	49	PZG-JEH12S-49	SOCKET HEAD CAP SCREW M8X20	1
08	PZG-JEH12S-08	PHILLIPS PAN HEAD MACHINE SCREW M6X12	2	50	PZG-JEH12S-50	LOCK PLATE FOR CLUTCH	1
09	PZG-JEH12S-09	STAY BOLT BLOCK FOR TOP HOOK ASSEMBLY	2	51	PZG-JEH12S-51	ROUND PIN A5X16	1
10	PZG-JEH12S-10	STAY BOLT FOR TOP HOOK ASSEMBLY	2	52	PZG-JEH12S-52	ADJUST ROUND NUT ASSEMBLY	1
11	PZG-JEH12S-11	MOTOR SIDE PLATE	1	55	PZG-JEH12S-55	PHILLIPS PAN HEAD MACHINE SCREW M4X16	1
12	PZG-JEH12S-12	TOP HOOK ASSEMBLY	1	56	PZG-JEH12S-56	PLAIN WASHER 4 MM	1
13	PZG-JEH12S-13	STAY BOLT FOR MOTOR SIDE PLATE	4	57	PZG-JEH12S-57	HEX NUT M4	1
14	PZG-JEH12S-14	BALL BEARING WITH RETAINER 150205	2	58	PZG-JEH12S-58	PHILLIPS PAN HEAD MACHINE SCREW M5X10	8
15	PZG-JEH12S-15	STOP RING 52/57.9	2	59	PZG-JEH12S-59	LOCK WASHER 5 MM	8
16	PZG-JEH12S-16	SHEAVE COVER	1	60	PZG-JEH12S-60	PLAIN WASHER 5 MM	8
17	PZG-JEH12S-17	LOCKNUT M6	1	61	PZG-JEH12S-61	SOCKET HEAD CAP SCREW M6X25	1
18	PZG-JEH12S-18	RUBBER PLUG	2	62	PZG-JEH12S-62	CHAIN CONTAINER BRACKET	1
19	PZG-JEH12S-19	SOCKET HEAD CAP SCREW M5X25	2	63	PZG-JEH12S-63	CHAIN CONTAINER	1
20	PZG-JEH12S-20	LOCK WASHER 5 MM	2	64	PZG-JEH12S-64	LIMIT SWITCH SET	1
21	PZG-JEH12S-21	LIFT WHEEL	1	65	PZG-JEH12S-65	SNAP RING 25 MM	1
22	PZG-JEH12S-22	GEAR SIDE PLATE	1	66	PZG-JEH12S-66	BLOCK	1
23	PZG-JEH12S-23	GEAR SIDE PLATE GASKET	2	67	PZG-JEH12S-67	CABLE INPUT SEAL	2
24	PZG-JEH12S-24	BALL BEARING WITH RETAINER 150201	1	68	PZG-JEH12S-68	LIMIT PADDLE ASSEMBLY	1
25	PZG-JEH12S-25	STOP RING 32/36.6	1	68-1	PZG-JEH12S-68-1	SIDE PLATE	2
26	PZG-JEH12S-26	SECOND GEAR SHAFT	1	68-2	PZG-JEH12S-68-2	CHAIN GUIDE BLOCK	1
27	PZG-JEH12S-27	SNAP RING 16 MM	1	68-3	PZG-JEH12S-68-3	CHAIN GUIDE SHAFT	1
28	PZG-JEH12S-28	LIFT GEAR	1	69	PZG-JEH12S-69	LIMIT SPRING	2
30	PZG-JEH12S-30	OVERLOAD LIMIT CLUTCH	1	70	PZG-JEH12S-70	LOAD CHAIN FOR 1/2T * Ø 6.3X19 MM	1
31	PZG-JEH12S-31	GEAR CASE SEAL	1	71	PZG-JEH12S-71	RETAINER RING	1
32	PZG-JEH12S-32	GEAR CASE	1	72	PZG-JEH12S-72	CHAIN STOP	1
33	PZG-JEH12S-33	SOCKET HEAD CAP SCREW M6X20	5	73	PZG-JEH12S-73	PIN	1
34	PZG-JEH12S-34	BALL BEARING 180202KZ1	1	74	PZG-JEH12S-74	BOTTOM HOOK ASSEMBLY FOR 1/2T	1
36	PZG-JEH12S-36	DC BRAKE FOR 1-PHASE	1	76	PZG-JEH12S-76	PHILLIPS PAN HEAD MACHINE SCREW M8X16	1
37	PZG-JEH12S-37	PHILLIPS PAN HEAD MACHINE SCREW M6X10	20	77	PZG-JEH12S-77	LOCK WASHER 8 MM	1
38	PZG-JEH12S-38	GEAR SIDE COVER ASSEMBLY. (WITH BALANCE BLOCK)	1	78	PZG-JEH12S-78	PLAIN WASHER 8 MM	1
39	PZG-JEH12S-39	CAPACITY LABEL FOR 1/2T	1	79	PZG-JEH12S-79	MOTOR COVER PACKING	2
40	PZG-JEH12S-40	SOCKET HEAD CAP SCREW M3X6	4	80	PZG-JEH12S-80	ELECTRIC COMPONENT BOARD FOR 1-PHASE	1
41	PZG-JEH12S-41	TRANSFORMER FOR 1-PHASE	1	81	PZG-JEH12S-81	RECTIFIER (FOR 1-PHASE ONLY) 60A	1
42	PZG-JEH12S-42	PHILLIPS PAN HEAD MACHINE SCREW M4X6	4	82	PZG-JEH12S-82	PHILLIPS PAN HEAD MACHINE SCREW M4X6	1

PARTS LIST: 1/2-TON CHAIN HOIST — REPLACEMENT PARTS — Prod. No. 107502

REF	PART NUMBER	DESCRIPTION	REQ
83	PZG-JEH12S-83	LOCK WASHER 4 MM	1
84	PZG-JEH12S-84	PLAIN WASHER 4 MM	1
85	PZG-JEH12S-85	FEMALE CONNECTOR FOR PUSH BUTTON CORD 7P	1
86	PZG-JEH12S-86	QUICK CONNECTOR BOARD	1
87	PZG-JEH12S-87	FEMALE CONNECTOR FOR POWER CORD 4P	1
88	PZG-JEH12S-88	CONTACTOR HOLDER FOR 1-PHASE	1
89	PZG-JEH12S-89	PHILLIPS PAN HEAD MACHINE SCREW M4X8	2
90	PZG-JEH12S-90	LOCK WASHER 4 MM	2
91	PZG-JEH12S-91	PLAIN WASHER 4 MM	2
92	PZG-JEH12S-92	MAGNETIC CONTACTOR FOR 1-PHASE	2
93	PZG-JEH12S-93	SOLID STATE SWITCH (1-PHASE ONLY)	1
94	PZG-JEH12S-94	PHILLIPS PAN HEAD MACHINE SCREW M3X16	2
95	PZG-JEH12S-95	SMALL WASHER 3 MM	2
96	PZG-JEH12S-96	CAPACITOR (1-PHASE ONLY) Ø65, 600UF	1
97	PZG-JEH12S-97	MOTOR SIDE COVER	1
98	PZG-JEH12S-98	PHILLIPS PAN HEAD MACHINE SCREW M3X12	8

REF	PART NUMBER	DESCRIPTION	REQ
99	PZG-JEH12S-99	PUSHBUTTON CONTROL FOR 1-PHASE AND 3-PHASE, SINGLE SPEED	1
100	PZG-JEH12S-100	MALE PLUG 7P	1
101	PZG-JEH12S-101	CABLE HOLDER	1
102	PZG-JEH12S-102	LOCK NUT M6	1
103	PZG-JEH12S-103	NAME PLATE	1
104	PZG-JEH12S-104	PHILLIPS PAN HEAD MACHINE SCREW M3X6	4
105	PZG-JEH12S-105	LOCK WASHER 3 MM	12
106	PZG-JEH12S-106	PLAIN WASHER 3 MM	12
107	PZG-JEH12S-107	FIRST GEAR SHAFT ASSEMBLY (FOR 1-PHASE ONLY)	1
108	PZG-JEH12S-108	CAPACITOR HOLDER (FOR 1-PHASE ONLY) Ø65	1
118	PZG-JEH12S-118	MALE PLUG 4P	1
123	PZG-JEH12S-123	LOCK NUT M3	8
124	PZG-JEH12S-124	CHAIN GUIDE	1
125	PZG-JEH12S-125	FUSE	1
126	PZG-JEH12S-126	FUSE COVER	1

HOOK ASSEMBLIES (1/2-TON) — PARTS BREAKDOWN — Prod. No. 107502

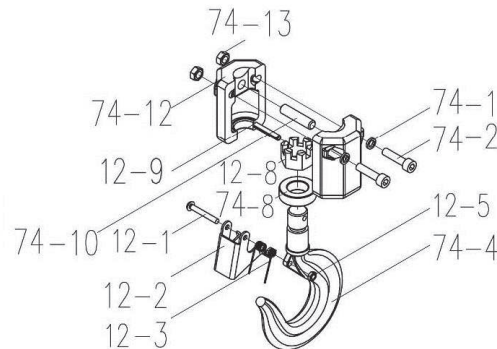
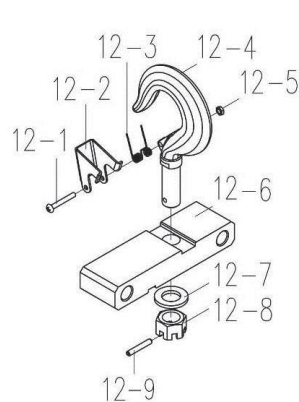

REF	PART NUMBER	DESCRIPTION	REQ
12-2	PZG-JEH12S-12-2	HOOK LATCH ASSEMBLY (INDEX # 12-1, 12-2, 12-3, 12-5)	2
12-4	PZG-JEH12S-12-4	TOP HOOK	1
12-6	PZG-JEH12S-12-6	CONNECTING BAR	1
12-7	PZG-JEH12S-12-7	PLAIN WASHER 16 MM	1
12-8	PZG-JEH12S-12-8	SLOTTED HEX NUT M16	1
12-9	PZG-JEH12S-12-9	ROLL PIN 4X28 MM	1

REF	PART NUMBER	DESCRIPTION	REQ
74-2	PZG-JEH12S-74-2	PHILLIPS PAN HEAD MACHINE SCREW M4X30	1
74-8	PZG-JEH12S-74-8	THRUST BALL BEARING 8103	2
74-4	PZG-JEH12S-74-4	BOTTOM HOOK	1
74-10	PZG-JEH12S-74-10	BOTTOM HOOK PIN	1
74-12	PZG-JEH12S-74-12	BOTTOM HOOK PIN	1
74-13	PZG-JEH12S-74-13	BOTTOM HOOK HOUSING	1
79-14	PZG-JEH12S-79-14	LOCK NUT M6	1

1-TON AND 2-TON CHAIN HOISTS — PARTS BREAKDOWN —

Prod. No. 107503, 107504, 107513, 107514

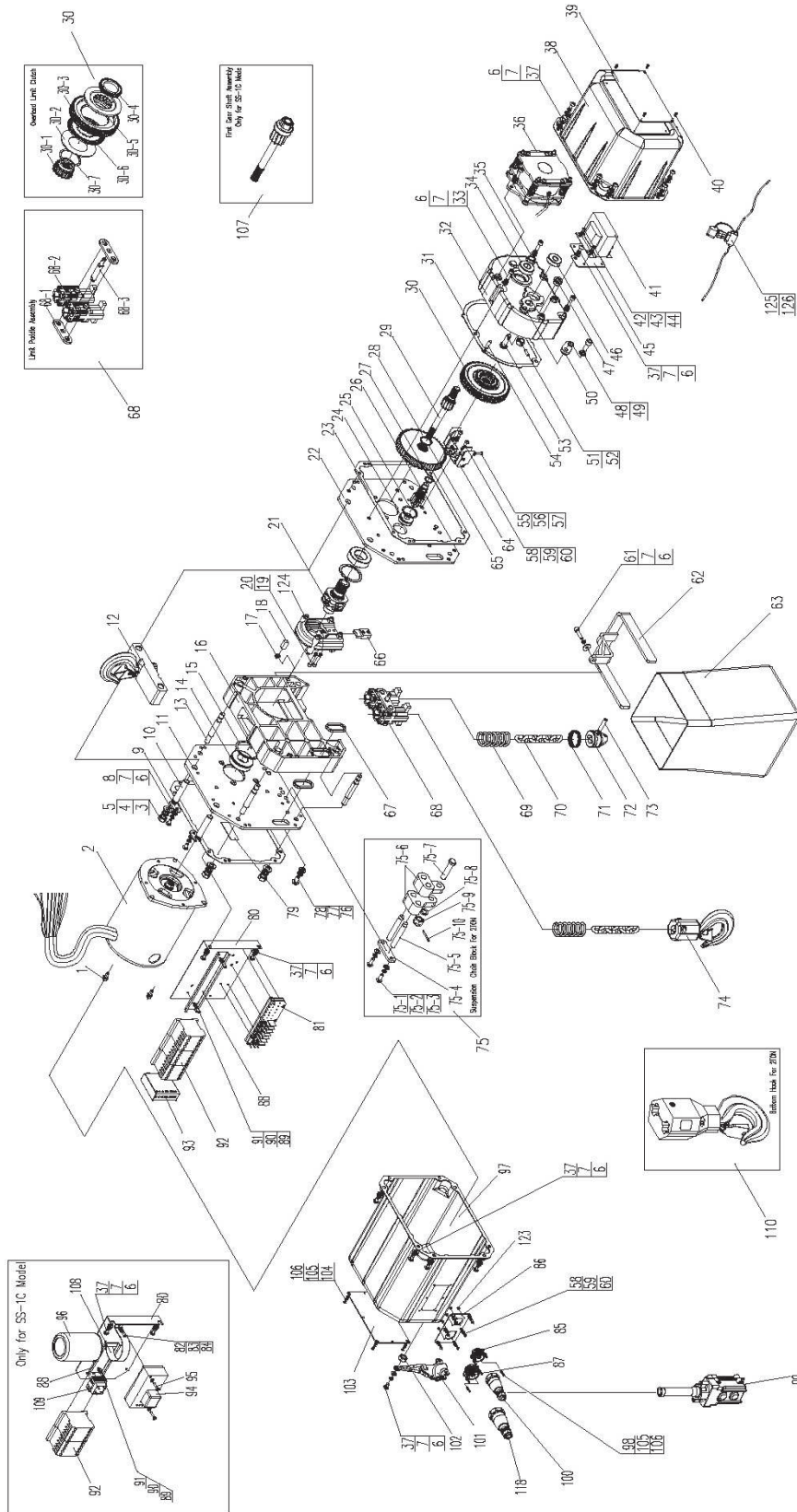

**PARTS LIST: 1-TON AND 2-TON CHAIN HOISTS —
REPLACEMENT PARTS — Prod. No. 107503, 107504, 107513, 107514**

REF	PART NUMBER	DESCRIPTION	REQ
01	PZG-JEH1S-01	MOTOR STAY BOLT (INCLUDES LOCK WASHER, PLAIN WASHER) M8X16	3
02	PZG-JEH1S-02	MOTOR ASSEMBLY FOR 1-PHASE	1
2	PZG-JEH1--02	MOTOR ASSEMBLY FOR 3-PHASE	1
03	PZG-JEH12S-03	HEX NUT M10	8
04	PZG-JEH12S-04	LOCK WASHER 10 MM	8
05	PZG-JEH12S-05	PLAIN WASHER 10 MM	8
06	PZG-JEH12S-06	PLAIN WASHER 6 MM	30
07	PZG-JEH12S-07	LOCK WASHER 6 MM	30
08	PZG-JEH12S-08	PHILLIPS PAN HEAD MACHINE SCREW M6X12	2
09	PZG-JEH1S-09	STAY BOLT BLOCK FOR TOP HOOK ASSEMBLY	2
10	PZG-JEH1S-10	STAY BOLT FOR TOP HOOK ASSEMBLY	2
11	PZG-JEH1S-11	MOTOR SIDE PLATE	1
12	PZG-JEH1S-12	TOP HOOK ASSEMBLY FOR 1-TON	1
12	PZG-JEH2S-12	TOP HOOK ASSEMBLY FOR 2-TON	1
13	PZG-JEH1S-13	STAY BOLT FOR MOTOR SIDE PLATE	4
14	PZG-JEH1S-14	BALL BEARING WITH RETAINER	2
15	PZG-JEH1S-15	STOP RING	2
16	PZG-JEH1S-16	SHEAVE COVER	1
17	PZG-JEH1S-17	LOCK NUT M 8	1
18	PZG-JEH1S-18	RUBBER PLUG	2
19	PZG-JEH1S-19	SOCKET HEAD CAP SCREW	2
20	PZG-JEH1S-20	LOCK WASHER	2
21	PZG-JEH1S-21	LIFT WHEEL	1
22	PZG-JEH1S-22	GEAR SIDE PLATE	1
23	PZG-JEH1S-23	GEAR SIDE PLATE GASKET	2
24	PZG-JEH1S-24	BALL BEARING WITH RETAINER	1
25	PZG-JEH1S-25	STOP RING	1
26	PZG-JEH1S-26	SECOND GEAR SHAFT	1
27	PZG-JEH1S-27	SNAP RING	1
28	PZG-JEH1S-28	LIFT GEAR	1
29	PZG-JEH1S-29	FIRST GEAR SHAFT 3-PHASE	1
30	PZG-JEH1S-30	OVERLOAD LIMIT CLUTCH FOR 1-PHASE	1
30	PZG-JEH1-30	OVERLOAD LIMIT CLUTCH FOR 3-PHASE	1
31	PZG-JEH1S-31	GEAR CASE SEAL	1
32	PZG-JEH1S-32	GEAR CASE	1
33	PZG-JEH12S-33	SOCKET HEAD CAP SCREW M6X20	5
34	PZG-JEH1S-34	BALL BEARING	1
35	PZG-JEH1S-35	SNAP RING (FOR 3-PHASE ONLY)	1
36	PZG-JEH1S-36	DC BRAKE FOR 1-PHASE	1
36	PZG-JEH1-36	DC BRAKE FOR 3-PHASE	1
37	PZG-JEH12S-37	PHILLIPS PAN HEAD MACHINE SCREW M6X10	20

REF	PART NUMBER	DESCRIPTION	REQ
38	PZG-JEH1S-38	GEAR SIDE COVER	1
39	PZG-JEH1S-39	CAPACITY LABEL FOR 1-TON	1
39	PZG-JEH1S-39	CAPACITY LABEL FOR 2-TON	1
40	PZG-JEH12S-40	SOCKET HEAD CAP SCREW M3X6	4
41	PZG-JEH12S-41	TRANSFORMER FOR 1-PHASE	1
41	PZG-JEH1-41	TRANSFORMER FOR 3-PHASE	1
42	PZG-JEH12S-42	PHILLIPS PAN HEAD MACHINE SCREW M4X6	4
43	PZG-JEH12S-43	LOCK WASHER 4 MM	4
44	PZG-JEH12S-44	PLAIN WASHER 4 MM	4
45	PZG-JEH12S-45	TRANSFORMER BRACKET	1
46	PZG-JEH1S-46	BALL BEARING	1
47	PZG-JEH1S-47	STEEL COLLAR	1
48	PZG-JEH1S-48	PLAIN WASHER	1
49	PZG-JEH12S-49	SOCKET HEAD CAP SCREW M8X20	1
50	PZG-JEH1S-50	LOCK PLATE FOR CLUTCH	1
51	PZG-JEH12S-51	ROUND PIN A5X16	1
52	PZG-JEH12S-52	ADJUST ROUND NUT ASSEMBLY	1
53	PZG-JEH1S-53	ADJUST SHAFT	1
54	PZG-JEH12S-54	ROUND PIN	2
55	PZG-JEH12S-55	PHILLIPS PAN HEAD MACHINE SCREW M4X16	1
56	PZG-JEH12S-56	PLAIN WASHER 4 MM	1
57	PZG-JEH12S-57	HEX NUT M4	1
58	PZG-JEH12S-58	PHILLIPS PAN HEAD MACHINE SCREW M5X10	8
59	PZG-JEH1S-59	LOCK WASHER	8
60	PZG-JEH1S-60	PLAIN WASHER	8
61	PZG-JEH1S-61	SOCKET HEAD CAP SCREW	1
62	PZG-JEH12S-62	CHAIN CONTAINER BRACKET	1
63	PZG-JEH1S-63	CHAIN CONTAINER	1
64	PZG-JEH12S-64	LIMIT SWITCH	1
65	PZG-JEH1S-65	SNAP RING	1
66	PZG-JEH1S-66	BLOCK	1
67	PZG-JEH1S-66	CABLE INPUT SEAL	2
68	PZG-JEH1S-68	LIMIT PADDLE ASSEMBLY	1
68-1	PZG-JEH1S-68-1	SIDE PLATE	2
68-2	PZG-JEH1S-68-2	CHAIN GUIDE BLOCK	1
68-3	PZG-JEH1S-68-3	CHAIN GUIDE SHAFT	1
69	PZG-JEH12S-69	LIMIT SPRING	2
70	105323	LOAD CHAIN FOR 1T, 2T, 3T, AND 5T *	1
71	PZG-JEH12S-71	RETAINER RING	1
72	PZG-JEH12S-72	CHAIN STOP	1
73	PZG-JEH12S-73	PIN	1
74	PZG-JEH1S-74	BOTTOM HOOK ASSEMBLY FOR 1-TON	1

PARTS LIST: 1-TON AND 2-TON CHAIN HOISTS — REPLACEMENT PARTS — Prod. No. 107503, 107504, 107513, 107514

REF	PART NUMBER	DESCRIPTION	REQ	REF	PART NUMBER	DESCRIPTION	REQ
75	PZG-JEH2S-75	SUSPENSION CHAIN BLOCK FOR 2-TON	1	90	PZG-JEH12S-90	LOCK WASHER 4 MM	2
75-1	PZG-JEH1S-75-1	PHILLIPS PAN HEAD MACHINE SCREW	2	91	PZG-JEH12S-91	PLAIN WASHER 4 MM	2
75-2	PZG-JEH12S-75-2	LOCK WASHER 6 MM	2	92	PZG-JEH12S-92	MAGNETIC CONTACTOR FOR 1-PHASE	2
75-3	PZG-JEH12S-75-3	PLAIN WASHER 6 MM	2	92	PZG-JEH1-92	MAGNETIC CONTACTOR FOR 3-PHASE	2
75-4	PZG-JEH1S-75-4	COVER	1	93	PZG-JEH12S-93	SOLID STATE SWITCH (1-PHASE ONLY)	1
75-5	PZG-JEH1S-75-5	SHAFT	2	94	PZG-JEH12S-94	PHILLIPS PAN HEAD MACHINE SCREW M3X16	2
75-6	PZG-JEH1S-75-6	CHAIN HOLDER	2	95	PZG-JEH12S-95	SMALL WASHER 3 MM	2
75-7	PZG-JEH1S-75-7	PIN	1	96	PZG-JEH12S-96	CAPACITOR (1-PHASE ONLY) Ø65, 600UF	1
75-8	PZG-JEH1S-75-8	PLAIN WASHER 8 MM	1	97	PZG-JEH1S-97	MOTOR SIDE COVER	1
75-9	PZG-JEH1S-75-9	SLOTTED HEX NUT	1	98	PZG-JEH12S-98	PHILLIPS PAN HEAD MACHINE SCREW M3X12	8
75-10	PZG-JEH1S-75-10	COTTON PIN	1	99	PZG-JEH12S-99	PUSHBUTTON CONTROL FOR 1-PHASE AND 3-PHASE, SINGLE SPEED	1
76	PZG-JEH1S-76	PHILLIPS PAN HEAD MACHINE SCREW	1	100	PZG-JEH12S-100	MALE PLUG 7P	1
77	PZG-JEH12S-77	LOCK WASHER 8 MM	1	101	PZG-JEH1S-101	CABLE HOLDER	1
78	PZG-JEH12S-78	PLAIN WASHER 8 MM	1	102	PZG-JEH1S-102	LOCK NT M6	1
79	PZG-JEH12S-79	MOTOR COVER PACKING	2	103	PZG-JEH1S-103	NAME PLATE 1-TON	1
80	PZG-JEH12S-80	ELECTRIC COMPONENT BOARD FOR 1-PHASE	1	103	PZG-JEH1S-103	NAME PLATE 2-TON	1
80	PZG-JEH1-80	ELECTRIC COMPONENT BOARD FOR 3-PHASE	1	104	PZG-JEH1S-104	PAN HEAD SCREW M3 X 6	4
81	PZG-JEH12S-81	RECTIFIER 1-PHASE	1	105	PZG-JEH1S-105	LOCK WASHER 3 MM	12
81	PZG-JEH1-81	RECTIFIER 3-PHASE	1	106	PZG-JEH1S-106	PLAIN WASHER 3 MM	12
82	PZG-JEH12S-82	PHILLIPS PAN HEAD MACHINE SCREW M4X6	1	107	PZG-JEH1S-107	FIRST GEAR SHAFT ASSEMBLY (FOR 1-PHASE ONLY)	1
83	PZG-JEH12S-83	LOCK WASHER 4 MM (1-PHASE ONLY)	1	108	PZG-JEH12S-108	CAPACITOR HOLDER (FOR 1-PHASE ONLY) Ø65	1
84	PZG-JEH12S-84	PLAIN WASHER 4 MM (1-PHASE ONLY)	1	110	PZG-JEH2S-110	BOTTOM HOOK ASSEMBLY FOR 2-TON	1
85	PZG-JEH12S-85	FEMALE CONNECTOR FOR PUSH BUTTON CORD 7P	1	112	PZG-JEH1S-112	FIRST GEAR SHAFT ASSEMBLY 1-PHASE	1
86	PZG-JEH12S-86	QUICK CONNECTOR BOARD	1	118	PZG-JEH12S-118	MALE PLUG 4P	1
87	PZG-JEH12S-87	FEMALE CONNECTOR FOR POWER CORD 4P	1	123	PZG-JEH12S-123	LOCK NUT M3	8
88	PZG-JEH1S-88	CONTACTOR HOLDER FOR 1-PHASE	1	124	PZG-JEH1S-124	CHAIN GUIDE	1
88	PZG-JEH1-88	CONTACTOR HOLDER FOR 3-PHASE	1	125	PZG-JEH1S-125	FUSE 2A	1
89	PZG-JEH12S-89	PHILLIPS PAN HEAD MACHINE SCREW M4X8	2	126	PZG-JEH1S-126	FUSE COVER	1

HOOK ASSEMBLIES (1-TON & 2-TON) — PARTS BREAKDOWN —

Prod. No. 107503, 107504, 105713, 107514

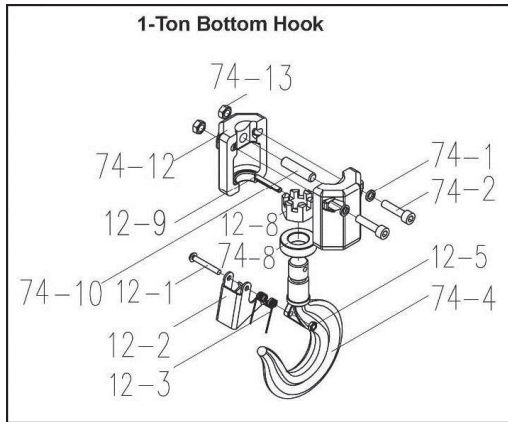
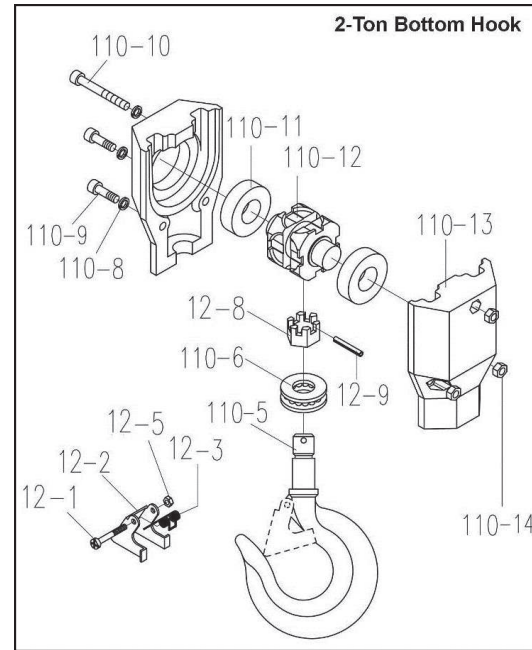
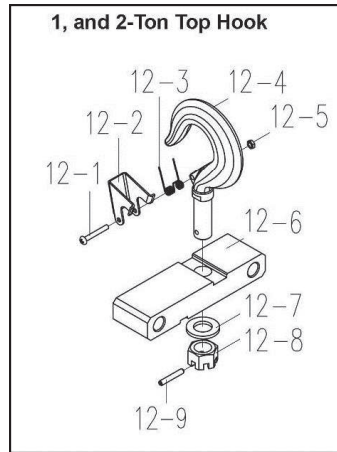

REF	PART NUMBER	DESCRIPTION	REQ
	PZG-JEH1S-12	TOP HOOK ASSEMBLY FOR 1-TON	1
12-1	PZG-JEH1S-12	1 T HOOK LATCH ASSEMBLY (INDEX #12-1, 12-2, 12-3, 12-5)	1
12-4	PZG-JEH1S-12-4	TOP HOOK 1-TON	1
12-6	PZG-JEH1S-12-6	CONNECTING BAR	1
12-7	PZG-JEH12S-12-7	PLAIN WASHER 16 MM	1
12-8	PZG-JEH12S-12-8	SLOTTED HEX NUT M16	1
12-9	PZG-JEH12S-12-9	ROLL PIN M4X28	1
	PZG-JEH1S-74	BOTTOM HOOK ASSEMBLY FOR 1-TON	1
74-1	PZG-JEH1S-74-01	LOCK WASHER 8 MM	2
74-2	PZG-JEH1S-74-02	SOCKET HEAD CAP SCREW M8X35	2
74-4	PZG-JEH1S-74-4	BOTTOM HOOK	1
74-8	PZG-JEH1S-74-8	THRUST BALL BEARING 8203	1
74-10	PZG-JEH1S-74-10	BOTTOM HOOK PIN	1
74-12	PZG-JEH1S-74-12	BOTTOM HOOK HOUSING	2
74-13	PZG-JEH1S-74-13	LOCK NUT M8	2
12	PZG-JEH2S-12	TOP HOOK ASSEMBLY FOR 2-TON	1

REF	PART NUMBER	DESCRIPTION	REQ
12-4	PZG-JEH2S-12-4	TOP HOOK 2-TON	1
12-5	PZG-JEH12S-12-5	LOCK NUT M4	1
12-6	PZG-JEH2S-12-6	CONNECTING BAR	1
12-7	PZG-JEH2S-12-7	PLAIN WASHER 20 MM	1
12-8	PZG-JEH2S-12-8	SLOTTED HEX NUT M20	1
12-9	PZG-JEH2S-12-9	ROLL PIN 4X30 MM	1
115	PZG-JEH2S-110	BOTTOM HOOK ASSEMBLY FOR 2-TON	1
12-0	PZG-JEH2S-12-0	2 T HOOK LATCH ASSEMBLY (INDEX #12-1, 12-2, 12-3, 12-5)	1
110-5	PZG-JEH2S-110-5	BOTTOM HOOK	1
110-6	PZG-JEH2S-110-6	THRUST BALL BEARING 8204	1
110-8	PZG-JEH1S-74-01	LOCK WASHER 8 MM	2
110-9	PZG-JEH2S-110-5	SOCKET HEAD CAP SCREW M8X25	2
110-10	PZG-JEH2S-110-5	SOCKET HEAD CAP SCREW M8X65	1
110-11	PZG-JEH2S-110-5	BALL BEARING 6305ZZ	2
110-12	PZG-JEH2S-110-5	SHEAVE	1
110-13	PZG-JEH2S-110-5	BOTTOM HOOK HOUSING	2
110-14	PZG-JEH1S-74-13	LOCK NUT M8	2

3-TON CHAIN HOIST — PARTS BREAKDOWN — Prod. No. 107505, 107515

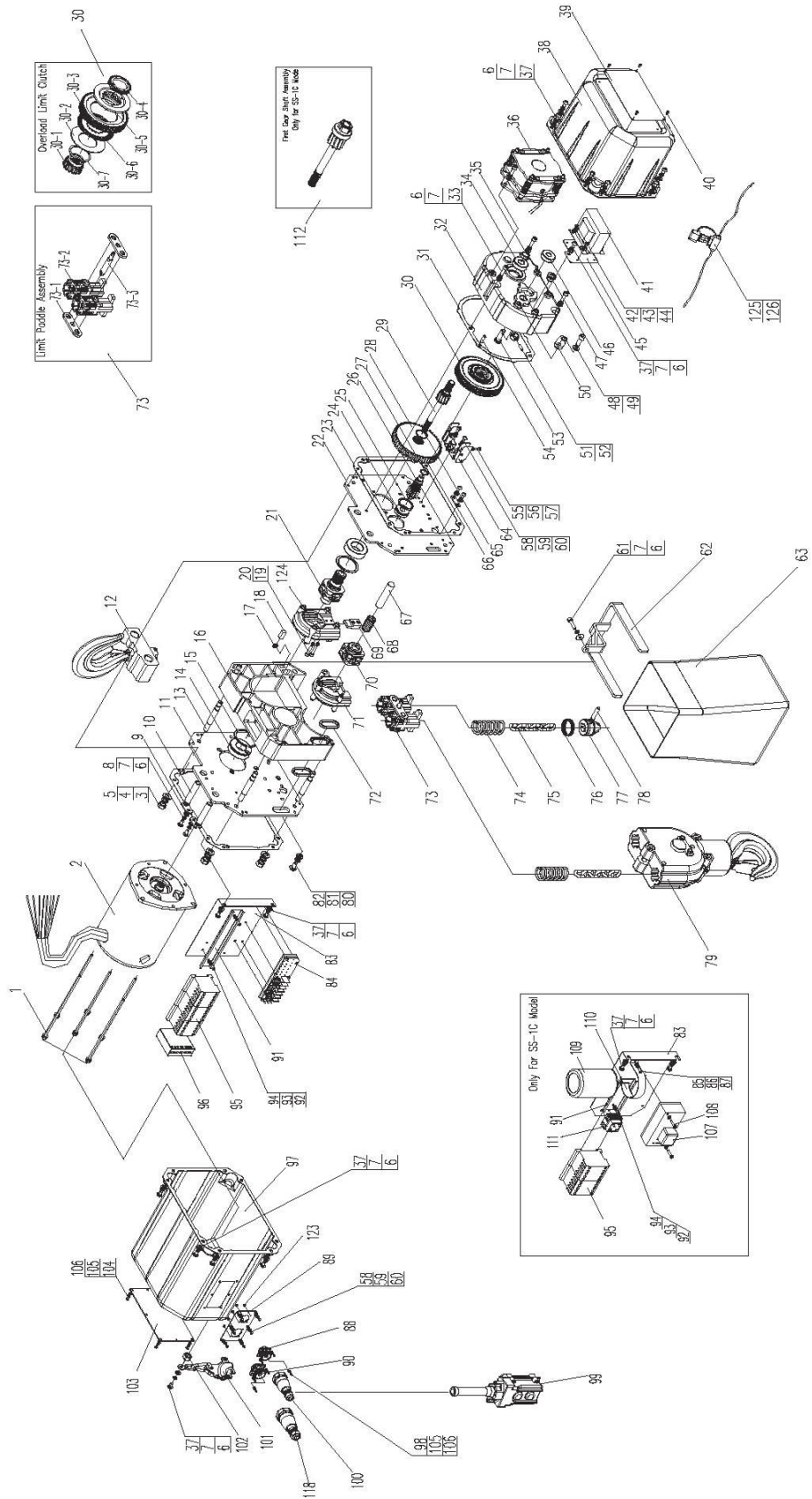

3-TON CHAIN HOIST — REPLACEMENT PARTS — Prod. No. 107505, 107515

REF	PART NUMBER	DESCRIPTION	REQ
01	PZG-JEH1S-01	MOTOR STAY BOLT (INCLUDES LOCK WASHER, PLAIN WASHER) M8X16	3
02	PZG-JEH1S-02	MOTOR ASSEMBLY FOR 1-PHASE	1
02	PZG-JEH3-02	MOTOR ASSEMBLY FOR 2-PHASE	1
03	PZG-JEH12S-03	HEX NUT M10	8
04	PZG-JEH12S-04	LOCK WASHER 10 MM	8
05	PZG-JEH12S-05	PLAIN WASHER 10 MM	8
06	PZG-JEH12S-06	PLAIN WASHER 6 MM	30
07	PZG-JEH12S-07	LOCK WASHER 6 MM	30
08	PZG-JEH12S-08	PHILLIPS PAN HEAD MACHINE SCREW M6X12	2
09	PZG-JEH1S-09	STAY BOLT BLOCK FOR TOP HOOK ASSEMBLY	2
10	PZG-JEH3-10	STAY BOLT FOR TOP HOOK ASSEMBLY	2
11	PZG-JEH3-11	MOTOR SIDE PLATE	1
12	PZG-JEH3-12	TOP HOOK ASSEMBLY	1
13	PZG-JEH1S-13	STAY BOLT FOR MOTOR SIDE PLATE	4
14	PZG-JEH1S-14	BALL BEARING WITH RETAINER	2
15	PZG-JEH1S-15	STOP RING	2
16	PZG-JEH3-16	SHEAVE COVER	1
17	PZG-JEH1S-17	LOCK NUT M8	1
18	PZG-JEH1S-18	RUBBER PLUG	2
19	PZG-JEH1S-19	SOCKET HEAD CAP SCREW	2
20	PZG-JEH1S-20	LOCK WASHER	2
21	PZG-JEH1S-21	LIFT WHEEL	1
22	PZG-JEH3-22	GEAR SIDE PLATE	1
23	PZG-JEH1S-23	GEAR SIDE PLATE GASKET	2
24	PZG-JEH1S-24	BALL BEARING WITH RETAINER	1
25	PZG-JEH1S-25	STOP RING	1
26	PZG-JEH1S-26	SECOND GEAR SHAFT	1
27	PZG-JEH1S-27	SNAP RING	1
28	PZG-JEH1S-28	LIFT GEAR	1
29	PZG-JEH1S-29	FIRST GEAR SHAFT FOR 3-PHASE ONLY	1
30	PZG-JEH1S-30	OVERLOAD LIMIT CLUTCH FOR 1-PHASE	1
30	PZG-JEH3-30	OVERLOAD LIMIT CLUTCH FOR 3-PHASE	1
31	PZG-JEH1S-31	GEAR CASE SEAL	1
32	PZG-JEH1S-32	GEAR CASE	1
33	PZG-JEH12S-08	SOCKET HEAD CAP SCREW	5
34	PZG-JEH1S-34	BALL BEARING	1
35	PZG-JEH1S-35	SNAP RING (FOR 3-PHASE ONLY)	1
36	PZG-JEH12S-36	DC BRAKE FOR 1-PHASE	1
36	PZG-JEH3-36	DC BRAKE FOR 3-PHASE	1
37	PZG-JEH12S-37	PAN HEAD MACHINE SCREW	20
38	PZG-JEH1S-38	GEAR SIDE COVER	1
39	PZG-JEH3-39	CAPACITY LABEL	1

REF	PART NUMBER	DESCRIPTION	REQ
40	PZG-JEH12S-40	SOCKET HEAD CAP SCREW M3X6	4
41	PZG-JEH12S-41	TRANSFORMER FOR 1-PHASE	1
41	PZG-JEH3-41	TRANSFORMER FOR 3-PHASE	1
42	PZG-JEH12S-42	PHILLIPS PAN HEAD MACHINE SCREW M4X6	4
43	PZG-JEH12S-43	LOCK WASHER 4 MM	4
44	PZG-JEH12S-44	PLAIN WASHER 4 MM	4
45	PZG-JEH12S-45	TRANSFORMER BRACKET	1
46	PZG-JEH1S-46	BALL BEARING	1
47	PZG-JEH1S-47	STEEL COLLAR	1
48	PZG-JEH1S-48	PLAIN WASHER	1
49	PZG-JEH12S-49	SOCKET HEAD CAP SCREW M8X20	1
50	PZG-JEH1S-50	LOCK PLATE FOR CLUTCH	1
51	PZG-JEH12S-51	ROUND PIN A5X16	1
52	PZG-JEH12S-52	ADJUST ROUND NUT ASSEMBLY	1
53	PZG-JEH1S-53	ADJUST SHAFT	1
54	PZG-JEH12S-54	ROUND PIN	2
55	PZG-JEH12S-55	PHILLIPS PAN HEAD MACHINE SCREW M4X16	1
56	PZG-JEH12S-56	PLAIN WASHER 4 MM	1
57	PZG-JEH12S-57	HEX NUT M4	1
58	PZG-JEH12S-58	PHILLIPS PAN HEAD MACHINE SCREW M5X10	8
59	PZG-JEH1S-59	LOCK WASHER	8
60	PZG-JEH1S-60	PLAIN WASHER	8
61	PZG-JEH1S-61	SOCKET HEAD CAP SCREW	1
62	PZG-JEH12S-62	CHAIN CONTAINER BRACKET	1
63	PZG-JEH3-63	CHAIN CONTAINER	1
64	PZG-JEH12S-64	LIMIT SWITCH	1
65	PZG-JEH1S-65	SNAP RING	1
66	PZG-JEH3-66	HINGE PLATE	1
67	PZG-JEH3-67	SHEAVE SHAFT	1
68	PZG-JEH3-68	NEEDLE	24
69	PZG-JEH1S-69	BLOCK	1
70	PZG-JEH3-70	SHEAVE	1
71	PZG-JEH3-71	SHEAVE GUIDE	1
72	PZG-JEH12S-67	CABLE INPUT SEAL	2
73	PZG-JEH1S-68	LIMIT PADDLE ASS	1
73-1	PZG-JEH1S-68-1	SIDE PLATE	2
73-2	PZG-JEH1S-68-2	CHAIN GUIDE BLOCK	1
73-3	PZG-JEH1S-68-3	CHAIN GUIDE SHAFT	1
74	PZG-JEH1S-69	LIMIT SPRING	2
75	105323	LOAD CHAIN	1
76	PZG-JEH1S-71	RETAINING RING	1
77	PZG-JEH1S-72	CHAIN STOP	1

3-TON CHAIN HOIST — REPLACEMENT PARTS — Prod. No. 107505, 107515

REF	PART NUMBER	DESCRIPTION	REQ	REF	PART NUMBER	DESCRIPTION	REQ
78	PZG-JEH1S-73	PIN	1	97	PZG-JEH12S-97	MOTOR SIDE COVER	1
79	PZG-JEH3-79	BOTTOM HOOK 3-TON	1	98	PZG-JEH12S-98	PHILLIPS PAN HEAD MACHINE SCREW M3X12	8
80	PZG-JEH1S-76	PAN HEAD SCREW	1	99	PZG-JEH12S-99	PUSHBUTTON CONTROL FOR 1-PHASE AND 3-PHASE, SINGLE SPEED	1
81	PZG-JEH12S-77	LOCK WASHER	1	100	PZG-JEH12S-100	MALE PLUG 7P	1
82	PZG-JEH12S-78	PLAIN WASHER	1	101	PZG-JEH12S-101	CABLE HOLDER	1
83	PZG-JEH12S-80	ELECTRIC COMPONENT BOARD FOR 1-PHASE	1	102	PZG-JEH12S-102	LOCK NUT M6	1
83	PZG-JEH3-83	ELECTRIC COMPONENT BOARD FOR 3-PHASE	1	103	PZG-JEH3-103-1	NAME PLATE 1-PHASE	1
84	PZG-JEH12S-81	RECTIFIER (FOR 1-PHASE ONLY) 60A	1	103	PZG-JEH3-103-2	NAME PLATE 3-PHASE	1
84	PZG-JEH3-84	RECTIFIER (FOR 3-PHASE ONLY) 50A	1	104	PZG-JEH12S-104	PHILLIPS PAN HEAD MACHINE SCREW M3X6	4
85	PZG-JEH12S-82	PHILLIPS PAN HEAD MACHINE SCREW M4X6 (FOR 1-PHASE ONLY)	1	105	PZG-JEH12S-105	LOCK WASHER 3 MM	8
86	PZG-JEH12S-83	LOCK WASHER 4 MM (FOR 1-PHASE ONLY)	1	106	PZG-JEH12S-106	PLAIN WASHER 3 MM	8
87	PZG-JEH12S-84	PLAIN WASHER 4 MM (FOR 1-PHASE ONLY)	1	107	PZG-JEH12S-93	SOLID STATE SWITCH (1-PHASE ONLY)	1
88	PZG-JEH12S-85	FEMALE CONNECTOR FOR PUSH BUTTON CORD 7P	1	108	PZG-JEH12S-94	PHILLIPS PAN HEAD MACHINE SCREW M3X16	2
89	PZG-JEH12S-86	QUICK CONNECTOR BOARD	1	109	PZG-JEH12S-95	SMALL WASHER 3 MM	2
90	PZG-JEH12S-87	FEMALE CONNECTOR FOR POWER CORD 4P	1	110	PZG-JEH12S-96	CAPACITOR (1-PHASE ONLY) Ø65, 600UF	1
91	PZG-JEH12S-88	CONTACTOR HOLDER FOR 1-PHASE	1	111	PZG-JEH12S-108	CAPACITOR HOLDER (FOR 1-PHASE ONLY) Ø65	1
91	PZG-JEH3-91	CONTACTOR HOLDER FOR 3-PHASE	1	112	PZG-JEH12S-107	FIRST GEAR SHAFT ASSEMBLY (FOR 1-PHASE ONLY)	1
92	PZG-JEH12S-89	PHILLIPS PAN HEAD MACHINE SCREW M4X8	2	118	PZG-JEH12S-118	MALE PLUG 4P	1
93	PZG-JEH12S-90	LOCK WASHER 4 MM	2	123	PZG-JEH12S-123	LOCK NUT M3	8
94	PZG-JEH12S-91	PLAIN WASHER 4 MM	2	124	PZG-JEH12S-124	CHAIN GUIDE	1
95	PZG-JEH12S-92	MAGNETIC CONTACTOR FOR 1-PHASE	2	125	PZG-JEH12S-125	FUSE	1
95	PZG-JEH3-95	MAGNETIC CONTACTOR FOR 3-PHASE, SINGLE SPEED	2	126	PZG-JEH12S-126	FUSE COVER	1

HOOK ASSEMBLIES (3-TON) — PARTS BREAKDOWN — Prod. No. 107505, 107515

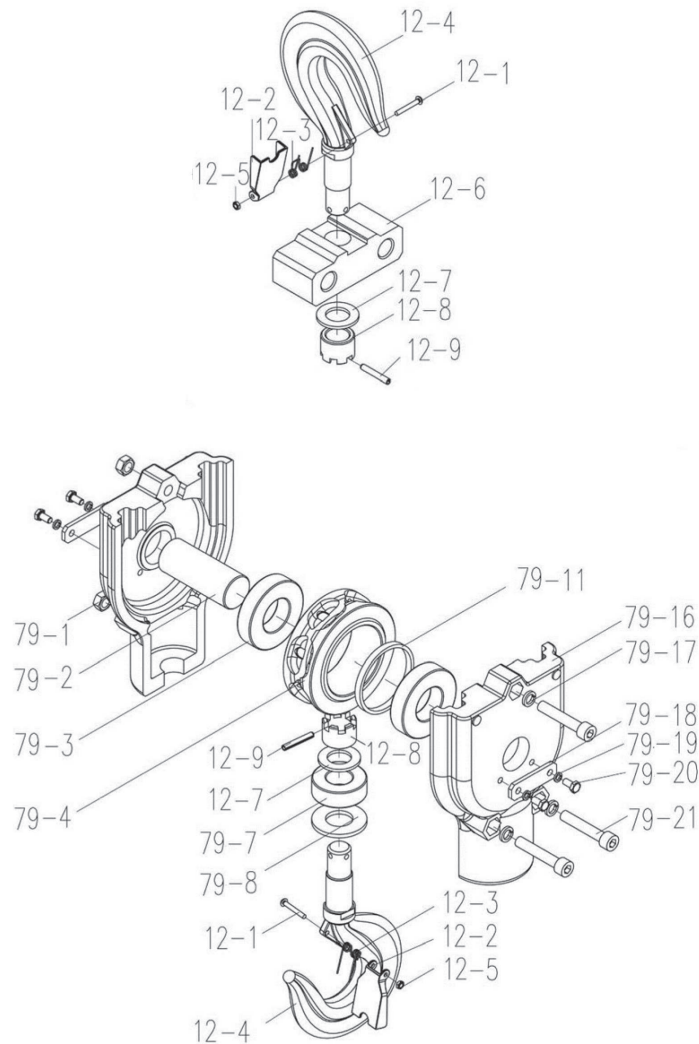

REF	PART NUMBER	DESCRIPTION	REQ
	PZG-JEH3-16	TOP HOOK ASSEMBLY FOR 3-TON	1
12-2	PZG-JEH3-12-2	HOOK LATCH ASSEMBLY (INDEX #12-1, 12-2, 12-3, 12-5)	1
12-4	PZG-JEH3-12-4	HOOK	1
12-6	PZG-JEH3-12-6	CONNECTING BAR	1
12-7	PZG-JEH3-12-7	COLLAR	1
12-8	PZG-JEH3-12-8	HOOK NUT	1
12-9	PZG-JEH3-12-9	ROLL PIN 5X35 MM	1
	PZG-JEH3-12-79	BOTTOM HOOK ASSEMBLY FOR 3-TON	1
12-4	PZG-JEH3-12-4	HOOK	1
12-7	PZG-JEH3-12-7	COLLAR	1
12-8	PZG-JEH3-12-8	HOOK NUT	1
12-9	PZG-JEH3-12-9	ROLL PIN 5X35 MM	1

REF	PART NUMBER	DESCRIPTION	REQ
79-1	PZG-JEH3-12-79-1	LOCK NUT M10	3
79-2	PZG-JEH3-12-79-2	SHEAVE SHAFT	1
79-3	PZG-JEH3-12-79-3	BALL BEARING 180207KZ1	2
79-4	PZG-JEH3-12-79-4	SHEAVE	1
79-7	PZG-JEH3-12-79-7	THRUST BALL BEARING 8305	1
79-8	PZG-JEH3-12-79-8	COLLAR	1
79-11	PZG-JEH3-12-79-11	COLLAR	1
79-16	PZG-JEH3-12-79-16	BOTTOM HOOK HOUSING	2
79-17	PZG-JEH3-12-79-17	LOCK WASHER 10 MM	3
79-18	PZG-JEH3-12-79-18	SHEAVE SHAFT BLOCK	2
79-19	PZG-JEH3-12-79-19	LOCK WASHER 6 MM	4
79-20	PZG-JEH3-12-79-20	HEX BOLT M6X12	4
79-21	PZG-JEH3-12-79-21	SOCKET HEAD CAP SCREW M10X55	3

5-TON CHAIN HOIST — PARTS BREAKDOWN — Prod. No. 107506, 107516

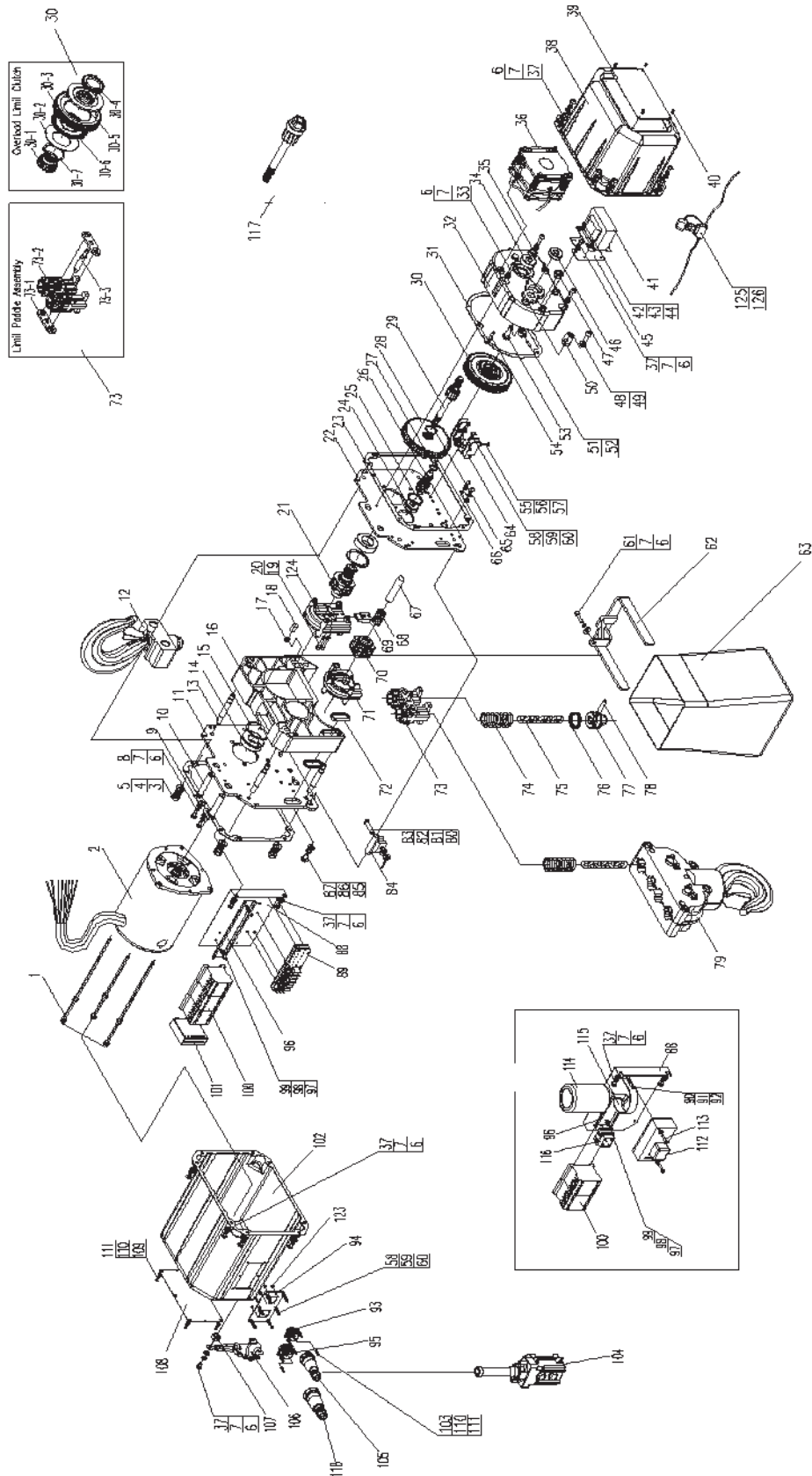

PARTS LIST: 5-TON CHAIN HOIST — REPLACEMENT PARTS — Prod. No. 107506, 107516

REF	PART NUMBER	DESCRIPTION	REQ	REF	PART NUMBER	DESCRIPTION	REQ
1	PZG-JEH1S-01	MOTOR STAY BOLT (INCLUDES LOCK WASHER, PLAIN WASHER) M8X16	3	38	PZG-JEH1S-38	GEAR SIDE COVER	1
2	PZG-JEH1S-02	MOTOR ASSEMBLY FOR 1-PHASE	1	39	PZG-JEH5-28	CAPACITY LABEL FOR 5-TON	1
2	PZG-JEH3-02	MOTOR ASSEMBLY FOR 3-PHASE	1	40	PZG-JEH12S-40	SOCKET HEAD CAP SCREW M3X6	4
3	PZG-JEH12S-03	HEX NUT M10	8	41	PZG-JEH12S-41	TRANSFORMER FOR 1-PHASE	1
4	PZG-JEH12S-04	LOCK WASHER 10 MM	8	41	PZG-JEH1-41	TRANSFORMER FOR 3-PHASE	1
5	PZG-JEH12S-05	PLAIN WASHER 10 MM	8	42	PZG-JEH12S-42	PHILLIPS PAN HEAD MACHINE SCREW M4X6	4
6	PZG-JEH12S-06	PLAIN WASHER 6 MM	30	43	PZG-JEH12S-43	LOCK WASHER 4 MM	4
7	PZG-JEH12S-07	LOCK WASHER 6 MM	30	44	PZG-JEH12S-44	PLAIN WASHER 4 MM	4
8	PZG-JEH12S-08	PHILLIPS PAN HEAD MACHINE SCREW M6X12	2	45	PZG-JEH12S-45	TRANSFORMER BRACKET	1
9	PZG-JEH1S-09	STAY BOLT BLOCK FOR TOP HOOK ASSEMBLY	2	46	PZG-JEH1S-46	BALL BEARING	1
10	PZG-JEH3-10	STAY BOLT FOR TOP HOOK ASSEMBLY	2	47	PZG-JEH1S-47	STEEL COLLAR	1
11	PZG-JEH5-11	MOTOR SIDE PLATE	1	48	PZG-JEH1S-48	PLAIN WASHER	1
12	PZG-JEH5-12	TOP HOOK ASSEMBLY FOR 1-TON	1	49	PZG-JEH12S-49	SOCKET HEAD CAP SCREW M8X20	1
13	PZG-JEH1S-13	STAY BOLT FOR MOTOR SIDE PLATE	4	50	PZG-JEH1S-50	LOCK PLATE FOR CLUTCH	1
14	PZG-JEH1S-14	BALL BEARING WITH RETAINER	2	51	PZG-JEH12S-51	ROUND PIN A5X16	1
15	PZG-JEH1S-15	STOP RING	2	52	PZG-JEH12S-52	ADJUST ROUND NUT ASSEMBLY	1
16	PZG-JEH3-16	SHEAVE COVER	1	53	PZG-JEH1S-53	ADJUST SHAFT	1
17	PZG-JEH1S-17	LOCK NUT M8	1	54	PZG-JEH12S-54	ROUND PIN	2
18	PZG-JEH1S-18	RUBBER PLUG	2	55	PZG-JEH12S-55	PHILLIPS PAN HEAD MACHINE SCREW M4X16	1
19	PZG-JEH1S-19	SOCKET HEAD CAP SCREW	2	56	PZG-JEH12S-56	PLAIN WASHER 4 MM	1
20	PZG-JEH1S-20	LOCK WASHER	2	57	PZG-JEH12S-57	HEX NUT M4	1
21	PZG-JEH1S-21	LIFT WHEEL	1	58	PZG-JEH12S-58	PHILLIPS PAN HEAD MACHINE SCREW M5X10	8
22	PZG-JEH5-22	GEAR SIDE PLATE	1	59	PZG-JEH1S-59	LOCK WASHER	8
23	PZG-JEH1S-23	GEAR SIDE PLATE GASKET	2	60	PZG-JEH1S-60	PLAIN WASHER	8
24	PZG-JEH1S-24	BALL BEARING WITH RETAINER	1	61	PZG-JEH1S-61	SOCKET HEAD CAP SCREW	1
25	PZG-JEH1S-25	STOP RING	1	62	PZG-JEH12S-62	CHAIN CONTAINER BRACKET	1
26	PZG-JEH5-12	SECOND GEAR SHAFT	1	63	PZG-JEH3-63	CHAIN CONTAINER	1
27	PZG-JEH1S-27	SNAP RING	1	64	PZG-JEH12S-64	LIMIT SWITCH	1
28	PZG-JEH5-28	LIFT GEAR	1	65	PZG-JEH1S-65	SNAP RING 34 MM	1
29	PZG-JEH1S-29	FIRST GEAR SHAFT FOR 3-PHASE ONLY	1	65	PZG-JEH1S-65	SNAP RING	1
30	PZG-JEH1S-30	OVERLOAD LIMIT CLUTCH FOR 1-PHASE	1	66	PZG-JEH3-66	HINGE PLATE	1
30	PZG-JEH1-30	OVERLOAD LIMIT CLUTCH FOR 3-PHASE	1	67	PZG-JEH3-67	SHEAVE SHAFT	1
31	PZG-JEH1S-31	GEAR CASE SEAL	1	68	PZG-JEH3-68	NEEDLE	24
32	PZG-JEH1S-32	GEAR CASE	1	69	PZG-JEH1S-69	BLOCK	1
33	PZG-JEH12S-33	SOCKET HEAD CAP SCREW M6X20	5	70	PZG-JEH3-70	SHEAVE	1
34	PZG-JEH1S-34	BALL BEARING	1	71	PZG-JEH3-71	SHEAVE GUIDE	1
35	PZG-JEH1S-35	SNAP RING (FOR 3-PHASE ONLY)	1	72	PZG-JEH12S-67	CABLE INPUT SEAL	2
36	PZG-JEH1S-36	DC BRAKE FOR 1-PHASE	1	73	PZG-JEH1S-68	LIMIT PADDLE ASSEMBLY	1
36	PZG-JEH3-36	DC BRAKE FOR 3-PHASE	1	73-1	PZG-JEH1S-68-1	SIDE PLATE	2
37	PZG-JEH12S-37	PHILLIPS PAN HEAD MACHINE SCREW M6X10	20	73-2	PZG-JEH1S-68-2	CHAIN GUIDE BLOCK	1
				73-3	PZG-JEH1S-68-3	CHAIN GUIDE SHAFT	1

PARTS LIST: 5-TON CHAIN HOIST — REPLACEMENT PARTS — Prod. No. 107506, 107516

REF	PART NUMBER	DESCRIPTION	REQ	REF	PART NUMBER	DESCRIPTION	REQ
74	PZG-JEH1S-69	LIMIT SPRING	2	98	PZG-JEH12S-90	LOCK WASHER 4 MM	2
75	105323	LOAD CHAIN	1	99	PZG-JEH12S-91	PLAIN WASHER 4 MM	2
76	PZG-JEH1S-71	RETAINING RING	1	100	PZG-JEH12S-92	MAGNETIC CONTACTOR FOR 1-PHASE	2
77	PZG-JEH1S-72	CHAIN STOP	1	100	PZG-JEH3-95	MAGNETIC CONTACTOR FOR 3-PHASE, SINGLE SPEED	2
78	PZG-JEH1S-73	PIN	1	102	PZG-JEH12S-97	MOTOR SIDE COVER	1
79	PZG-JEH5-79	BOTTOM HOOK 5-TON	1	103	PZG-JEH12S-98	PHILLIPS PAN HEAD MACHINE SCREW M3X12	8
80	PZG-JEH1S-75-7	PIN	1	104	PZG-JEH12S-99	PUSHBUTTON CONTROL FOR 1-PHASE AND 3-PHASE, SINGLE SPEED	1
81	PZG-JEH12S-78	PLAIN WASHER	1	105	PZG-JEH12S-100	MALE PLUG 7P	1
82	PZG-JEH5-82	SLOTTED HEX NUT	1	106	PZG-JEH12S-101	CABLE HOLDER	1
83	PZG-JEH5-83	COTTOR PIN	1	107	PZG-JEH12S-102	LOCK NUT M6	1
84	PZG-JEH5-84	CHAIN HOLDER	1	108	PZG-JEH5-108	NAME PLATE 5-TON 1-PHASE	1
85	PZG-JEH12S-82	PHILLIPS PAN HEAD MACHINE SCREW M8X16	1	108	PZG-JEH5-108	NAME PLATE 5-TON 3-PHASE	1
86	PZG-JEH12S-83	LOCK WASHER 8 MM	1	109	PZG-JEH12S-104	PHILLIPS PAN HEAD MACHINE SCREW M3X6	4
87	PZG-JEH12S-84	PLAIN WASHER 8 MM	1	110	PZG-JEH12S-105	LOCK WASHER 3 MM	12
88	PZG-JEH12S-80	ELECTRIC COMPONENT BOARD FOR 1-PHASE	1	111	PZG-JEH12S-106	PLAIN WASHER 3 MM	12
88	PZG-JEH3-83	ELECTRIC COMPONENT BOARD FOR 3-PHASE	1	112	PZG-JEH12S-93	SOLID STATE SWITCH (1-PHASE ONLY)	1
89	PZG-JEH12S-81	RECTIFIER (FOR 1-PHASE ONLY) 60A	1	113	PZG-JEH12S-94	PHILLIPS PAN HEAD MACHINE SCREW M3X16	2
89	PZG-JEH3-84	RECTIFIER (FOR 3-PHASE ONLY) 50A	1	114	PZG-JEH12S-95	SMALL WASHER 3 MM	2
90	PZG-JEH12S-82	PHILLIPS PAN HEAD MACHINE SCREW M4X6 1-PHASE	1	115	PZG-JEH12S-96	CAPACITOR (1-PHASE ONLY) Ø65, 600UF	1
91	PZG-JEH12S-83	LOCK WASHER 4 MM 1-PHASE	1	116	PZG-JEH12S-108	CAPACITOR HOLDER (FOR 1-PHASE ONLY) Ø65	1
92	PZG-JEH12S-84	PLAIN WASHER 4 MM 1-PHASE	1	117	PZG-JEH12S-107	FIRST GEAR SHAFT ASSEMBLY (FOR 1-PHASE ONLY)	1
93	PZG-JEH12S-85	FEMALE CONNECTOR FOR PUSH BUTTON CORD 7P	1	118	PZG-JEH12S-118	MALE PLUG 4P	1
94	PZG-JEH12S-86	QUICK CONNECTOR BOARD	1	123	PZG-JEH12S-123	LOCK NUT M3	8
95	PZG-JEH12S-87	FEMALE CONNECTOR FOR POWER CORD 4P	1	124	PZG-JEH12S-124	CHAIN GUIDE	1
96	PZG-JEH12S-88	CONTACTOR HOLDER FOR 1-PHASE	1	125	PZG-JEH12S-125	FUSE	1
96	PZG-JEH3-91	CONTACTOR HOLDER FOR 3-PHASE	1	126	PZG-JEH12S-126	FUSE COVER	1
97	PZG-JEH12S-89	PHILLIPS PAN HEAD MACHINE SCREW M4X8	2				

PARTS LIST: HOOK ASSEMBLIES (5-TON ONLY) — REPLACEMENT PARTS —
Prod. No. 107506, 107516

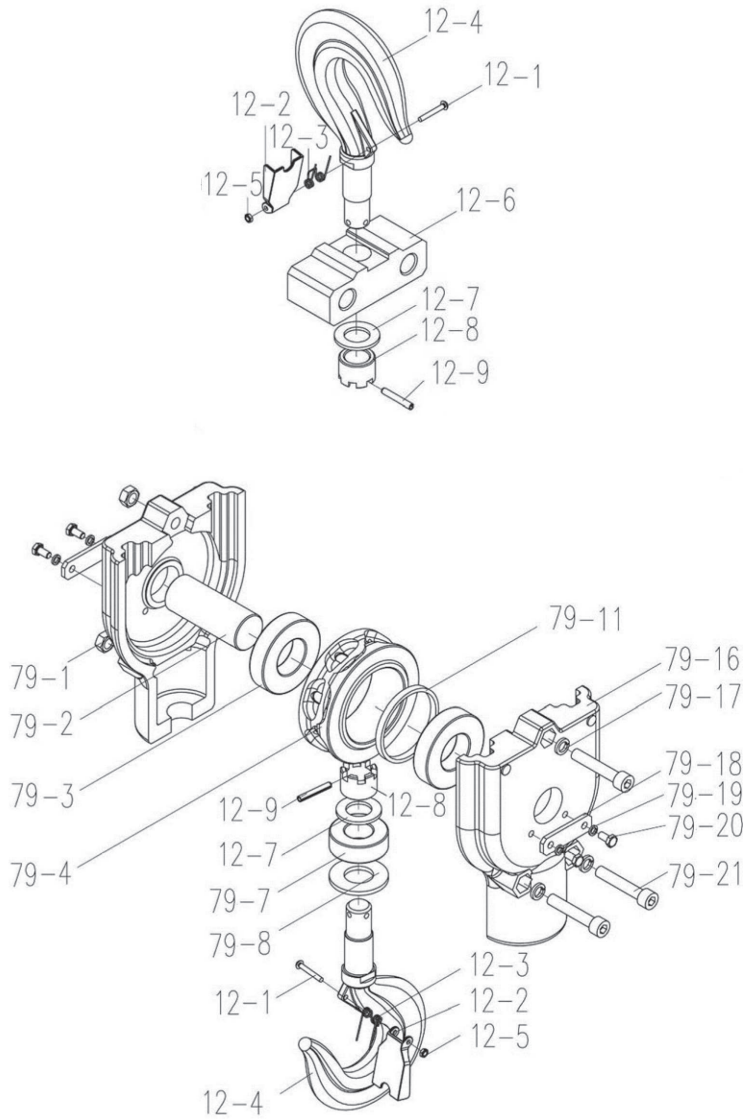

REF	PART NUMBER	DESCRIPTION	REQ
12	PZG-JEH5-12	TOP HOOK ASSEMBLY FOR 5-TON	1
12-4	PZG-JEH5-12-4	TOP HOOK	1
12-6	PZG-JEH5-12-6	CONNECTING BAR	1
12-7	PZG-JEH5-12-7	PLAIN WASHER	1
12-8	PZG-JEH5-12-8	HOOK NUT	1
12-9	PZG-JEH5-12-9	ROLL PIN 5X40 MM	1
79	PZG-JEH5-79	BOTTOM HOOK ASSEMBLY FOR 5-TON	1
79-1	PZG-JEH5-79-1	SOCKET HEAD CAP SCREW M10X65	4
79-2	PZG-JEH12S-04	LOCK WASHER 10 MM	4
79-3	PZG-JEH5-79-3	BOTTOM HOOK HOUSING	2
79-6	PZG-JEH5-79-6	PLAIN WASHER	1
79-7	PZG-JEH5-79-7	THRUST BALL BEARING 8306	1

REF	PART NUMBER	DESCRIPTION	REQ
74-8	PZG-JEH5-74-8	COLLAR	1
12-0	PZG-JEH5-12-0	HOOK LATCH ASSEMBLY (INDEX #12-1, 12-2, 12-3, 12-5)	1
12-8	PZG-JEH5-12-8	HOOK NUT	1
12-9	PZG-JEH5-12-9	ROLL PIN 5X40 MM	1
79-14	PZG-JEH3-79-20	HEX BOLT M6X12	8
79-15	PZG-JEH12S-07	LOCK WASHER 6 MM	8
79-16	PZG-JEH12S-08	PLAIN WASHER 6 MM	8
79-17	PZG-JEH5-74-17	HINGE PLATE	4
79-18	PZG-JEH3-74-18	LOCK NUT M10	4
79-19	PZG-JEH3-74-19	NEEDLE 3X39.8B	48
79-20	PZG-JEH3-79-18	SHEAVE	2
79-21	PZG-JEH3-79-21	SHEAVE SHAFT	2

ELECTRICAL CONNECTIONS: 1-PHASE

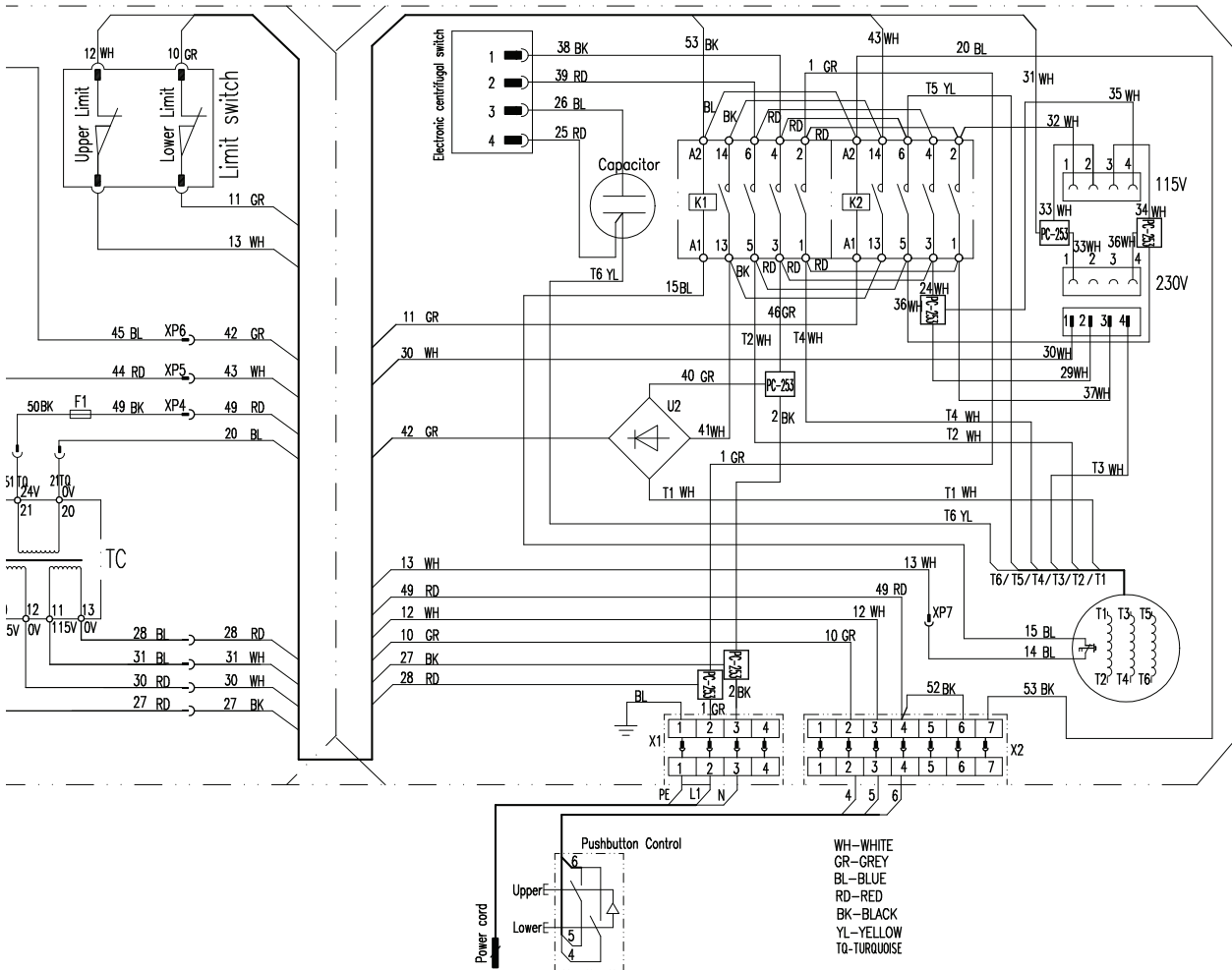

WIRING DIAGRAM FOR ELECTRIC HOISTS IN 1 PHASE WITH SINGLE SPEED

Wiring Diagram for Electric Hoists in 1-Phase with Single Speed

ELECTRICAL CONNECTIONS: 3-PHASE

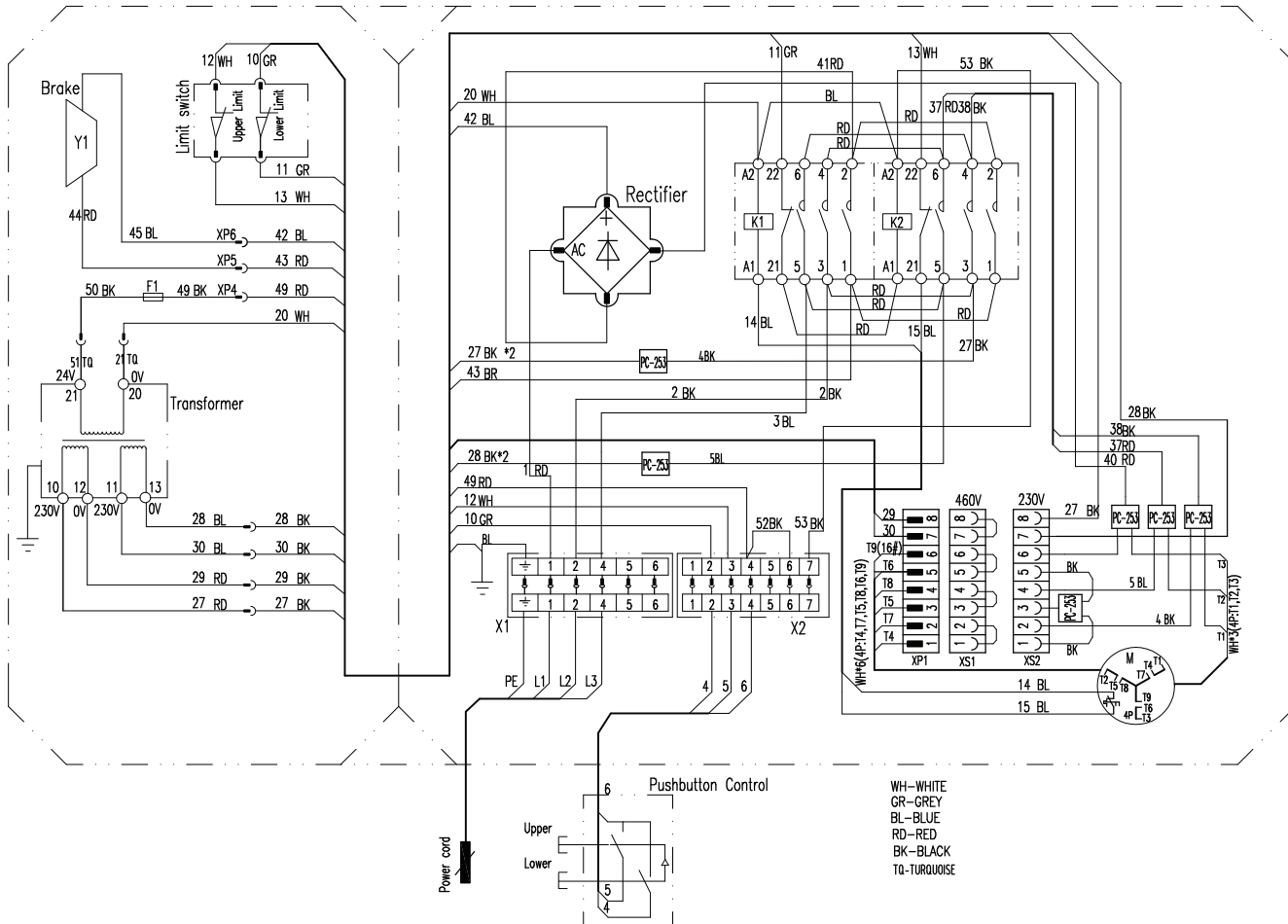

WIRING DIAGRAM FOR ELECTRIC HOISTS IN 3 PHASE WITH SINGLE SPEED

Wiring Diagram for Electric Hoists in 3-Phase with Single Speed