

Operation MANUAL

90 Litre Waste Oil Drain - Heavy Duty

Prod. No. 350511
Mod. No. JOIDR90



Failure to heed the following warnings may result in personal injury and/or property damage. Do not drain caustic or flammable products. NEVER use near open flame or heat source. NEVER pressurize tank with evacuation valve closed. Do not do any welding on the reservoir. While draining high-temperature oils, keep hands and face protected. Do not modify any component of the equipment. Only use original spare parts. Do not overfill tank. NEVER leave unit unattended while operating or evacuating. Always disconnect air supply after evacuating.

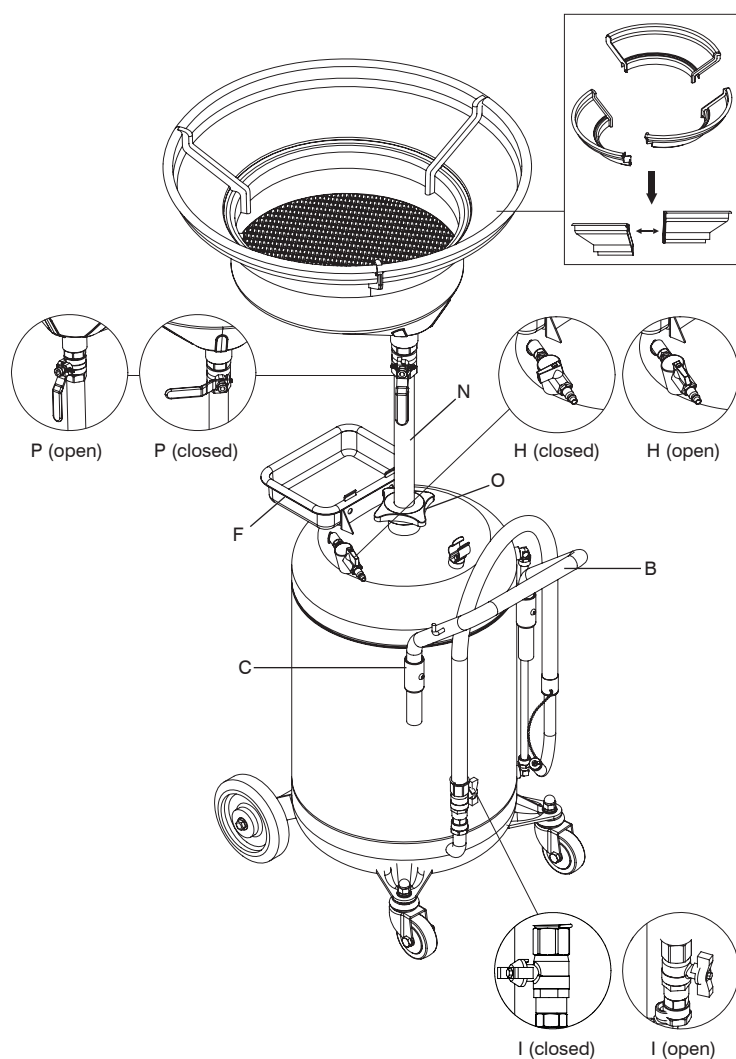

Owner / User Responsibility

The owner and/or user must have a thorough understanding of the manufacturer's operating instructions and warnings before using this equipment. Personnel involved in the use and operation of this equipment shall be careful, competent, trained, and qualified in the safe operation of the equipment and its proper use when servicing motor vehicles and their components. Warning information should be emphasized and understood. If the operator is not fluent in English, the manufacturer's instructions and warnings shall be read to and discussed with the operator in the operator's native language by the purchaser / owner, making sure that the operator comprehends its contents.

Owner and/or user must study and keep for future reference the manufacturer's instructions. Owner and/or user is responsible for keeping all warning labels and instruction manuals legible and intact.

Assembly

- 1) Insert handle (B) into seat (C) and secure with screws provided, position tool tray (F)
- 2) Insert drain tube (N) into tank assembly and tighten lock (O)
- 3) Attach bowl assembly to ball valve assembly (P) on drain tube

Operating Instructions

To Drain Oil:

With drain tube valve (P) fully open, raise bowl to desired height and lock in place with Lock (O). Drain oil into bowl / tank assembly. DO NOT OVERFILL TANK, check level gauge on side of tank while draining. While transporting tank, ensure bowl is in the lowered position and use tank handle (B).

To Evacuate Tank:

Close drain tube valve (P). Place drain hose end into bulk storage tank and secure. Open evacuation hose valve (I). Attach air supply to air valve (H) (air pressure 7 PSI, NOTE: Unit is equipped with a safety valve calibrated to 14 PSI). NEVER LEAVE UNIT UNATTENDED WHILE EVACUATING. Disconnect air supply when evacuation is finished.



No.	Description	Qty.
1-1	Check Nut	1
1-2	Compression Spring	1
*1-3	O-Ring	2
1-4	Sealing Bush	1
*1-5	O-Ring	4
1-6	Expansion Cover	1
1-7	Hand Wheel	1
1-8	Supporting Tube	1
*1-9	Ball Valve	1
1-10	Nut	1
1-11	Retainer Sleeve	1
1-12	Oil Collecting Bowl	1
1-13	Filtration Plank	1
*1-14	Extension Funnel	1

No.	Description	Qty.
2-1	Reservoir Assembly	1
2-2	Handle	1
2-3	Screw	3
2-4	Butterfly Valve	1
2-5	Swivel Fitting	1
2-6	Bolts	2
2-7	Wheel	2
2-8	Castor	2
2-9	Spring Washer	2
2-10	Gasket	2
2-11	Nuts	2
2-12	Elbow	2
2-13	Nut	2
2-14	Tube with Label	1
2-15	Clip	1

*Wearing Parts

